

SUPPLEMENTAL EXERCISE PROBLEMS
for Textbook

**Kinematics, Dynamics, and Design of
Machinery**

by
K. J. Waldron and G. L. Kinzel



©1996-97 by K. Waldron and G. Kinzel

Department of Mechanical Engineering



Supplemental Exercise Problems
for
Kinematics, Dynamics, and Design of Machinery
by
K. J. Waldron and G. L. Kinzel

Supplemental Exercise Problems for Chapter 1

Problem S1.1

What are the number of members, number of joints, and mobility of each of the planar linkages shown below?

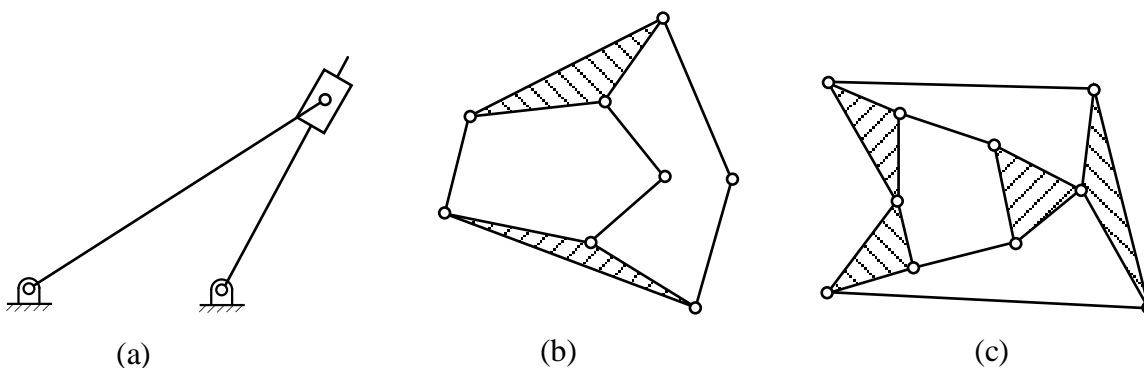

Problem S1.2

Determine the mobility and the number of idle degrees of freedom of each of the planar linkages shown below. Show the equations used to determine your answers.

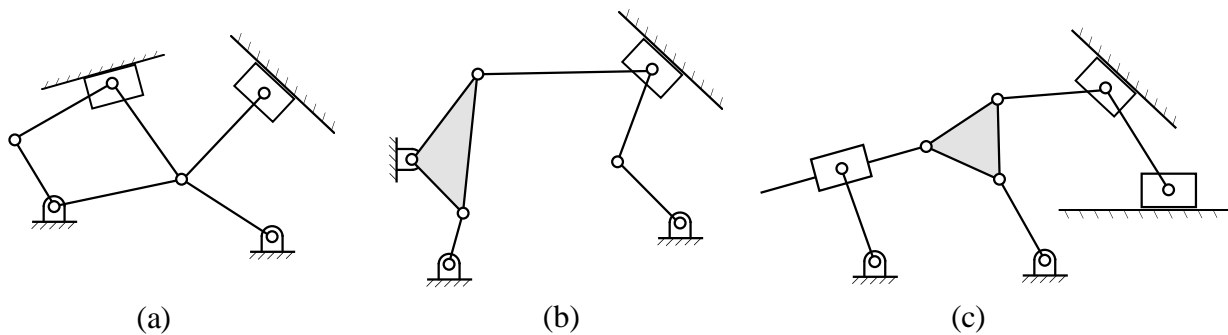

Problem S1.3

Determine the mobility and the number of idle degrees of freedom of the linkages shown below. Show the equations used to determine your answers.

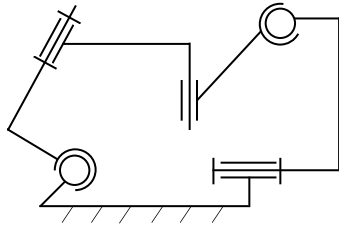

(a)

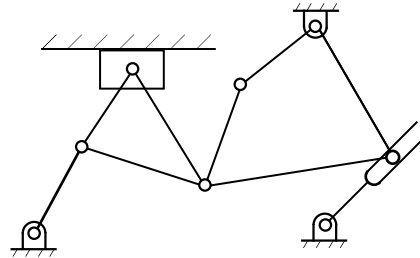

(b)

Problem S1.4

Determine the mobility and the number of idle degrees of freedom associated with the mechanism. Show the equations used to determine your answers.

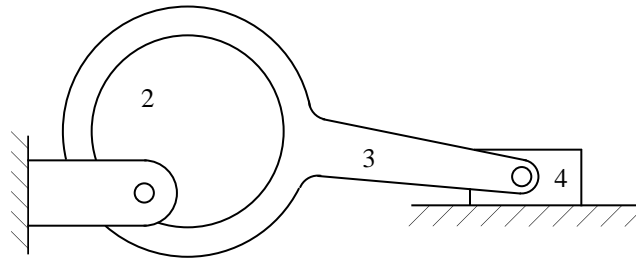

Problem S1.5

If the link lengths of a four-bar linkage are $L_1 = 1$ mm, $L_2 = 3$ mm, $L_3 = 4$ mm, and $L_4 = 5$ mm and link 1 is fixed, what type of four-bar linkage is it? Also, is the linkage a Grashof type 1 or 2 linkage? Answer the same questions if $L_1 = 2$ mm.

Problem S1.6

You are given two sets of links. Select four links from each set such that the coupler can rotate fully with respect to the others. Sketch the linkage and identify the type of four-bar mechanism.

a) $L_1 = 5''$, $L_2 = 8''$, $L_3 = 15''$, $L_4 = 19''$, and $L_5 = 28''$

b) $L_1 = 5''$, $L_2 = 2''$, $L_3 = 4''$, $L_4 = 3.5''$, and $L_5 = 2.5''$

Supplemental Exercise Problems for Chapter 2

Problem S2.1

Draw the velocity polygon to determine the following:

- a) Sliding velocity of link 6
- b) Angular velocities of links 3 and 5

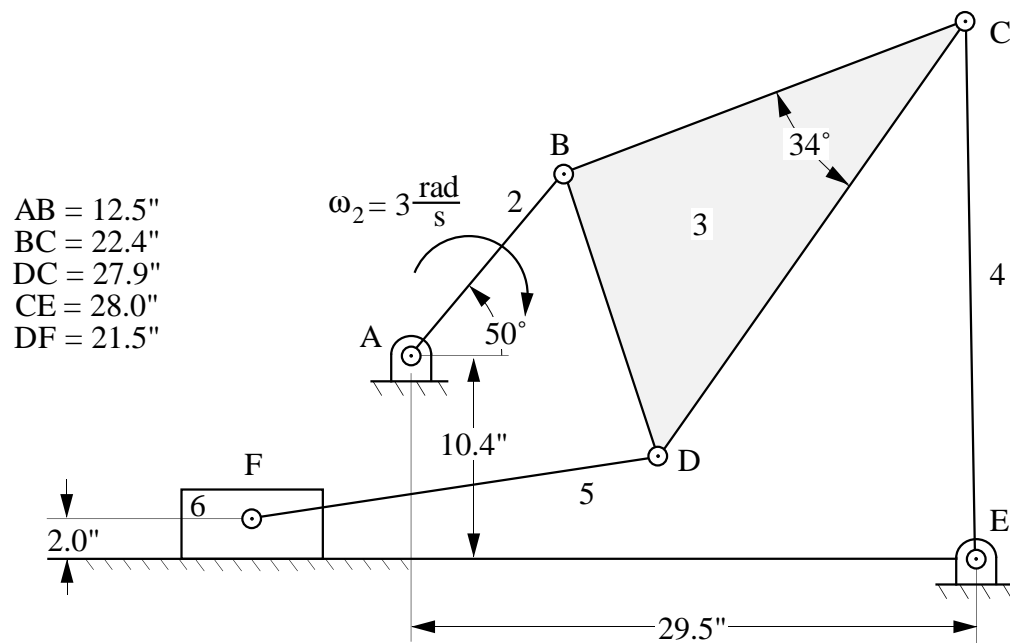

Problem S2.2

In the mechanism shown, ${}^1v_{A_2} = 15 \text{ m/s}$. Draw the velocity polygon, and determine the velocity of point D on link 6 and the angular velocity of link 5 (show all calculations).

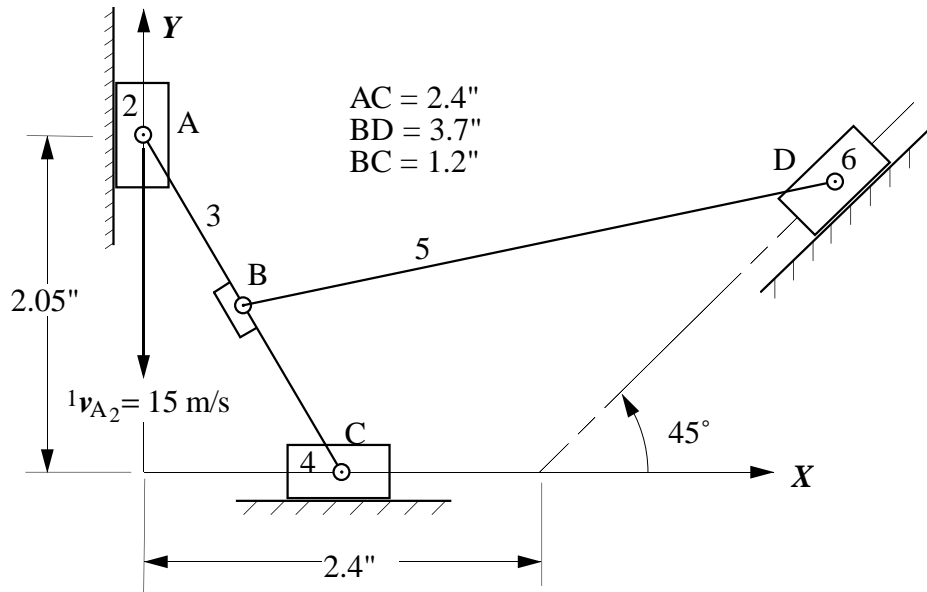

Problem S2.3

In the mechanism shown below, points E and B have the same vertical coordinate. Find the velocities of points B, C, and D of the double-slider mechanism shown in the figure if Crank 2 rotates at 42 rad/s CCW.

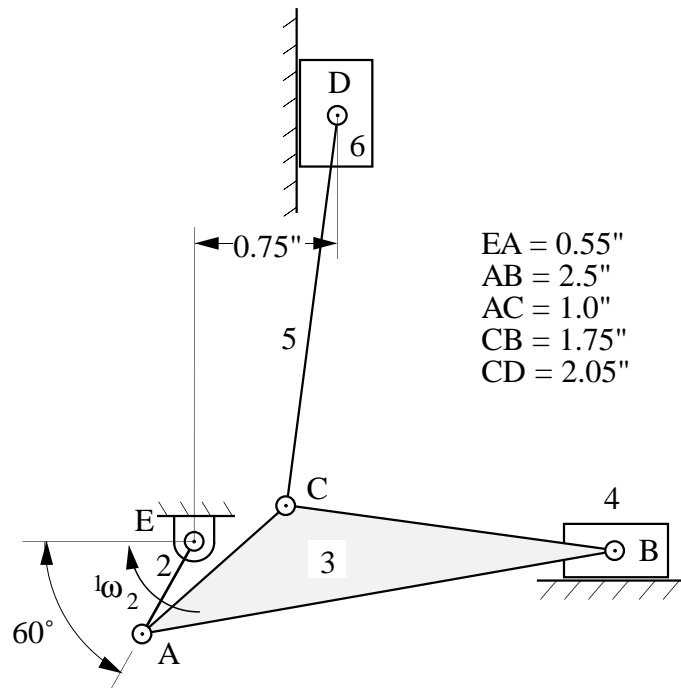

Problem S2.4

In the figure below, points A and C have the same horizontal coordinate, and ${}^1\omega_3 = 30 \text{ rad/s}$. Draw and dimension the velocity polygon. Identify the sliding velocity between the block and the slide, and find the angular velocity of link 2.

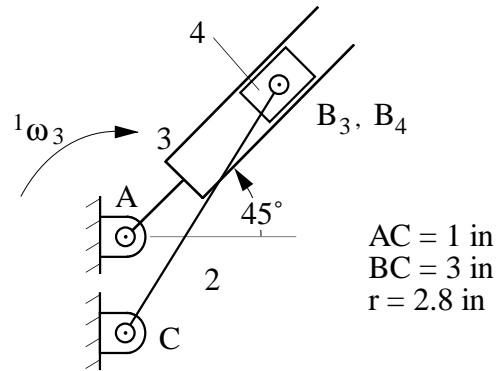

Problem S2.5

The following are given for the mechanism shown in the figure:

$${}^1\omega_2 = 6.5 \text{ rad/s (CCW)}; \quad {}^1\alpha_2 = 40 \text{ rad/s}^2 \text{ (CCW)}$$

Draw the velocity polygon, and locate the velocity of Point E using the image technique.

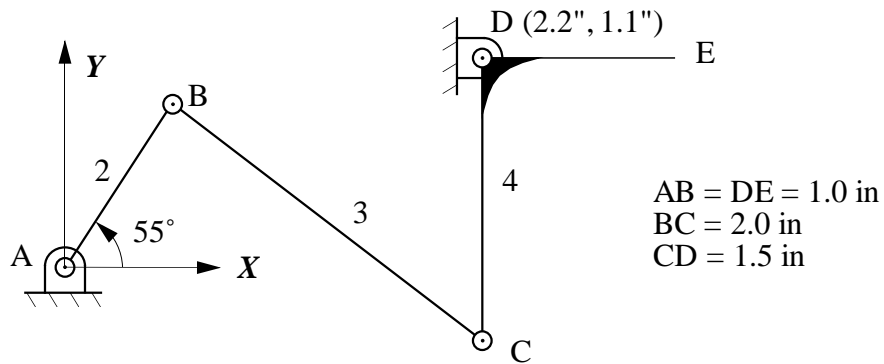

Problem S2.6

In the mechanism shown, link 4 moves to the left with a velocity of 8 in/s and the acceleration is 80 in/s^2 to the left. Draw the velocity and acceleration polygons and solve for the angular velocity and acceleration of link 2.

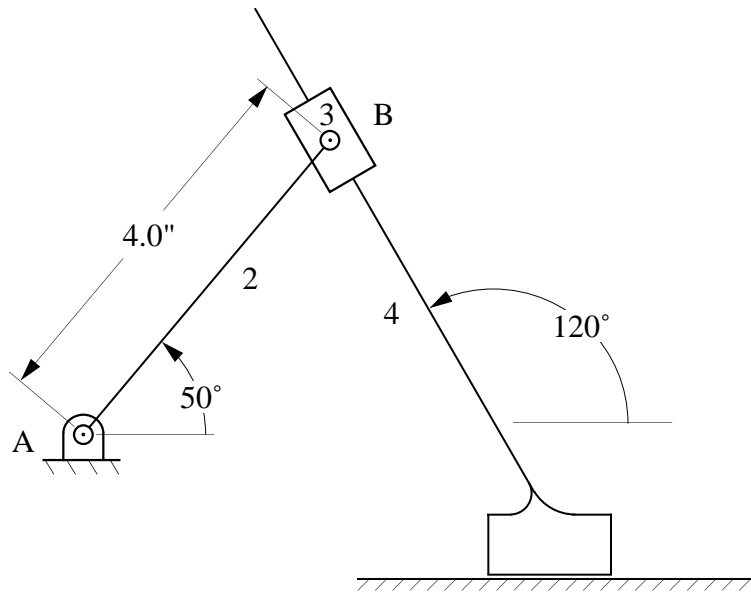

Problem S2.7

In the mechanism shown below, link 2 is turning CCW at the rate of 10 rad/s (constant). Draw the velocity and acceleration polygons for the mechanism, and record values for ${}^1\mathbf{a}_{G_3}$ and ${}^1\alpha_4$.

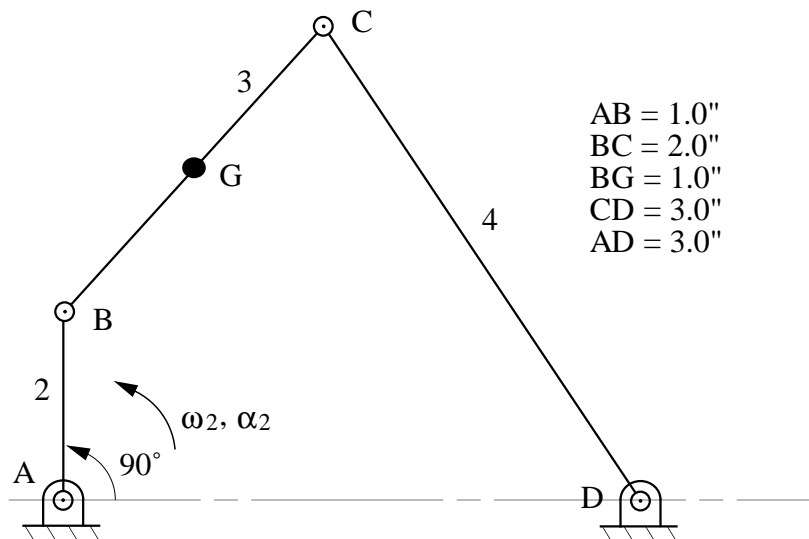

Problem S2.8

For the data given in the figure below, find the velocity and acceleration of points B and C. Assume ${}^1v_A = 20 \text{ ft/s}$, ${}^1a_A = 400 \text{ ft/s}^2$, ${}^1\omega_2 = 24 \text{ rad/s}$ (CW), and ${}^1\alpha_2 = 160 \text{ rads}^2$ (CCW).

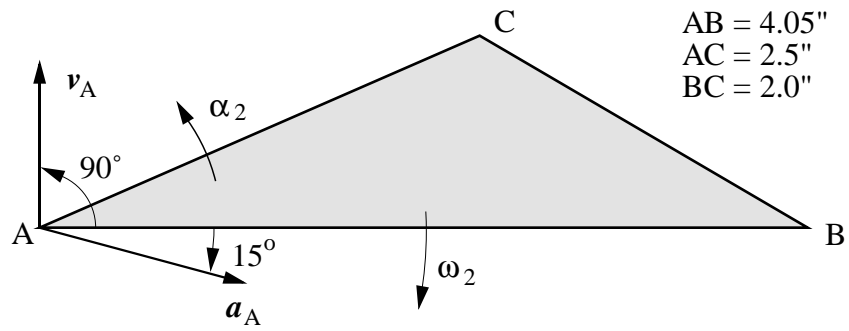

Problem S2.9

In the mechanism shown, find ${}^1\omega_6$ and ${}^1\alpha_3$. Also, determine the acceleration of D_3 by image.

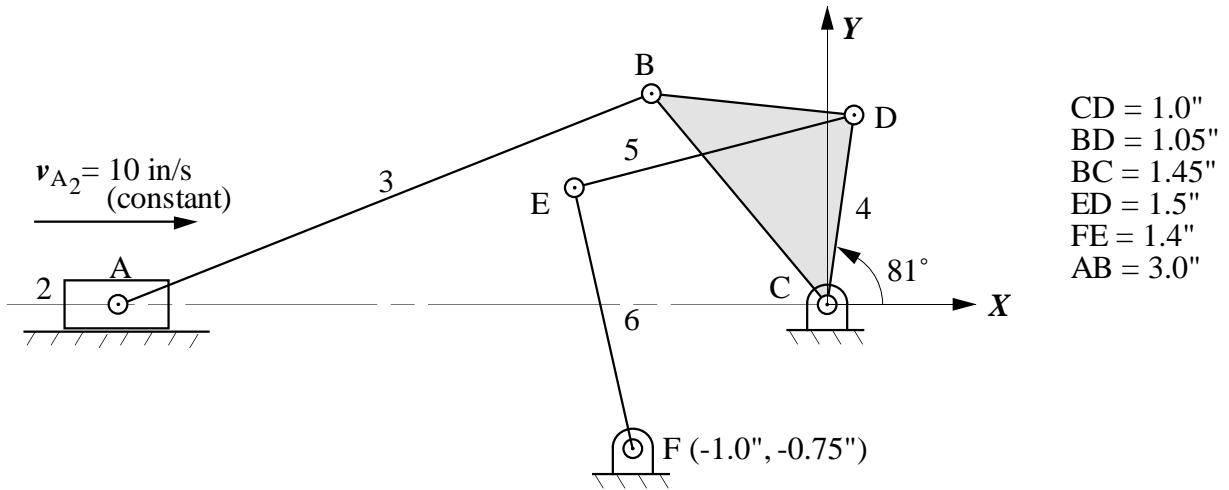

Problem S2.10

In the mechanism shown, ${}^1\omega_2 = 1 \text{ rad/s}$ (CCW) and ${}^1\alpha_2 = 0 \text{ rad/s}^2$. Find ${}^1\omega_5$, ${}^1\alpha_5$, ${}^1v_{E6}$, ${}^1a_{E6}$ for the position given. Also find the point in link 5 that has zero acceleration for the position given.

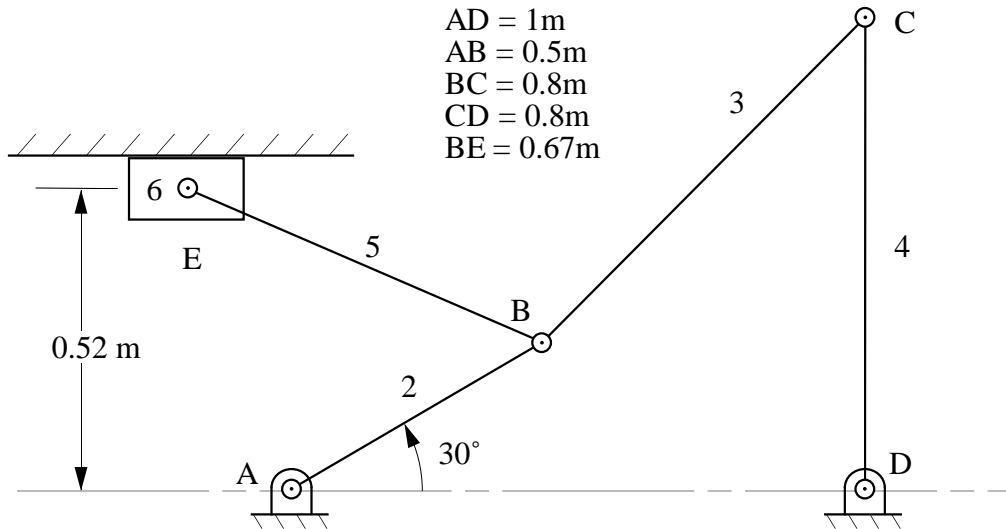

Problem S2.11

Part of an eight-link mechanism is shown in the figure. Links 7 and 8 are drawn to scale, and the velocity and acceleration of point D_7 are given. Find ${}^1\omega_7$ and ${}^1\alpha_7$ for the position given. Also find the velocity of G_7 by image.

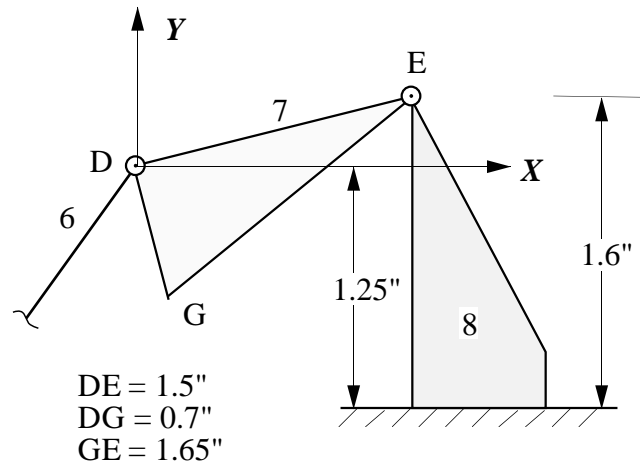

$$v_{D7} = 5.0 \angle 320^\circ \text{ in/sec} \quad a_{D7} = 40 \angle 260^\circ \text{ in/s}^2$$

Problem S2.12

In the figure shown below, points A, B, and C are collinear. If ${}^1v_{A_2} = 10$ in/s (constant) downward, find ${}^1v_{C_3}$, and ${}^1a_{C_3}$.

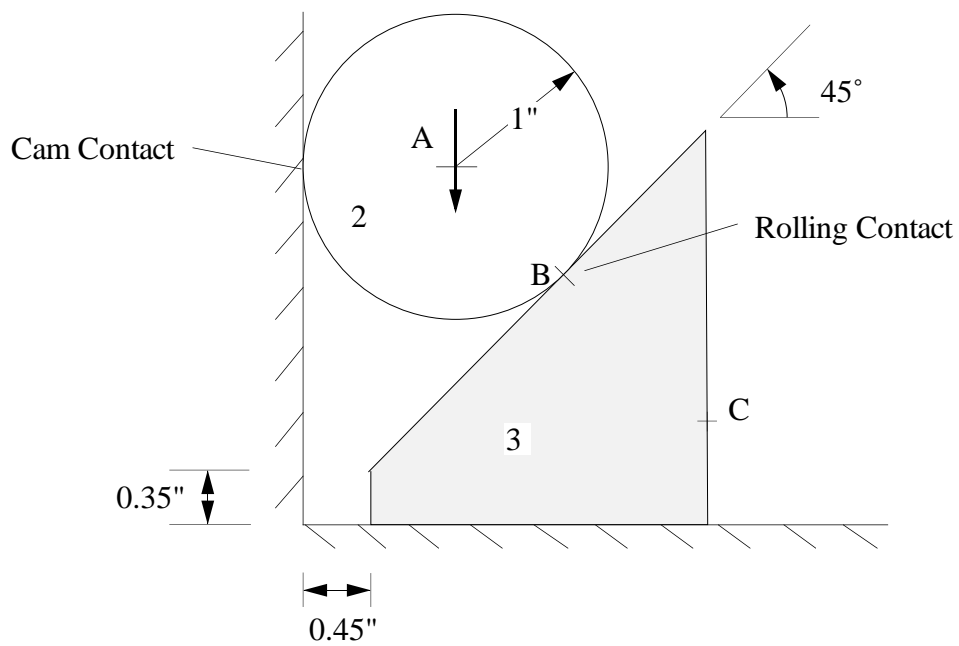

Problem S2.13

Part of an eight-link mechanism is shown in the figure. There is rolling contact at location B. Links 7 and 8 are drawn to scale, and the velocity and acceleration of points A₆ and C₅ are as shown. Find ${}^1\omega_8$ and ${}^1\alpha_7$ for the position given. Also find the velocity of E₇ by image.

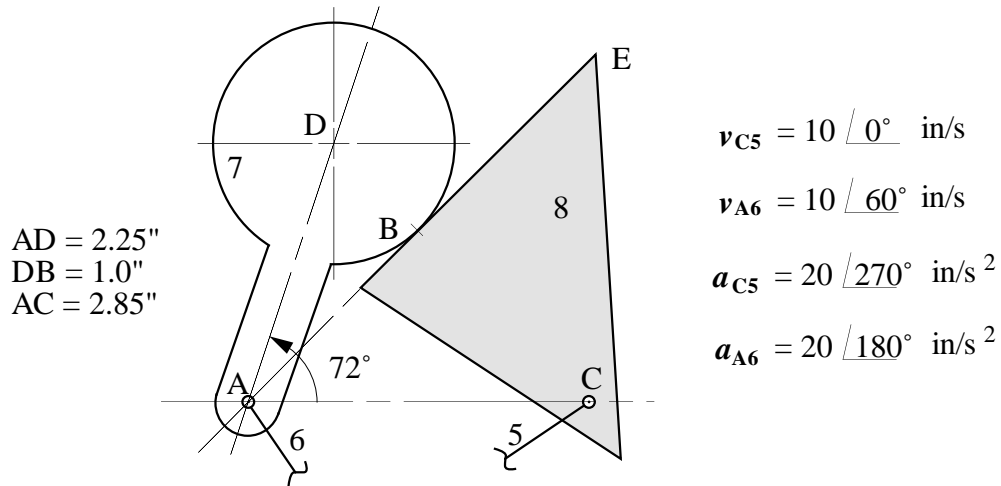

Problem S2.14

In the position shown, find the velocity and acceleration of link 3 using (1) equivalent linkages and (2) direct approach.

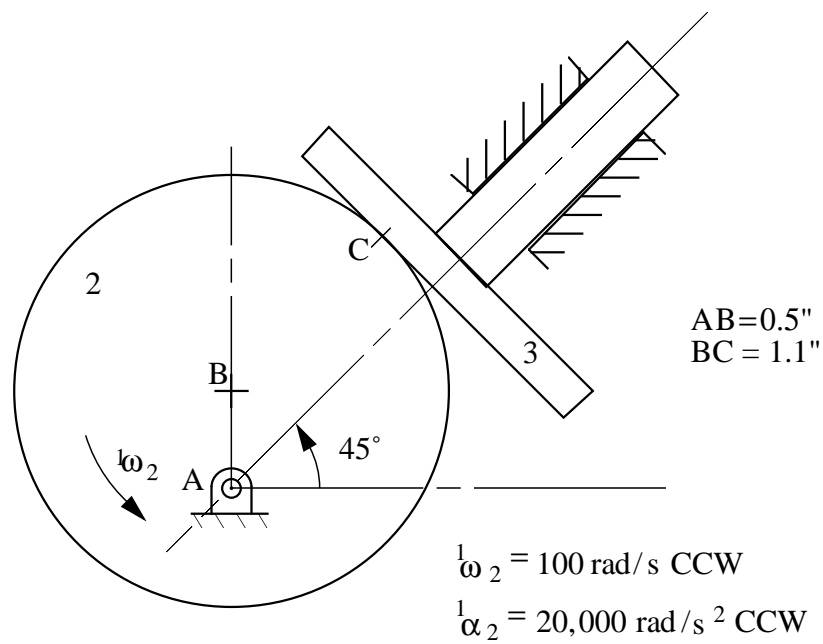

Problem S2.15

For the mechanism shown, find ${}^1\omega_3$, ${}^1\alpha_3$, ${}^1\mathbf{a}_{B_3}$, and the location of the center of curvature of the path that point B_3 traces on link 2.

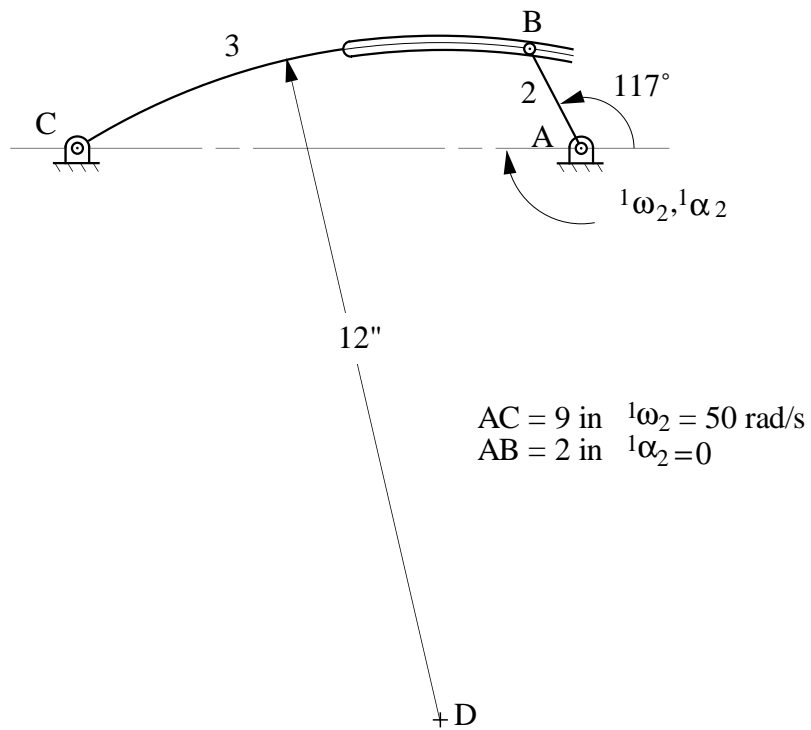

Problem S2.17

If the mechanism shown is drawn full scale, find ${}^1\omega_3$, ${}^1\alpha_3$, and the location of the center of curvature of the path that point B_3 traces on Link 2. Assume that Link 2 is driven at constant velocity.

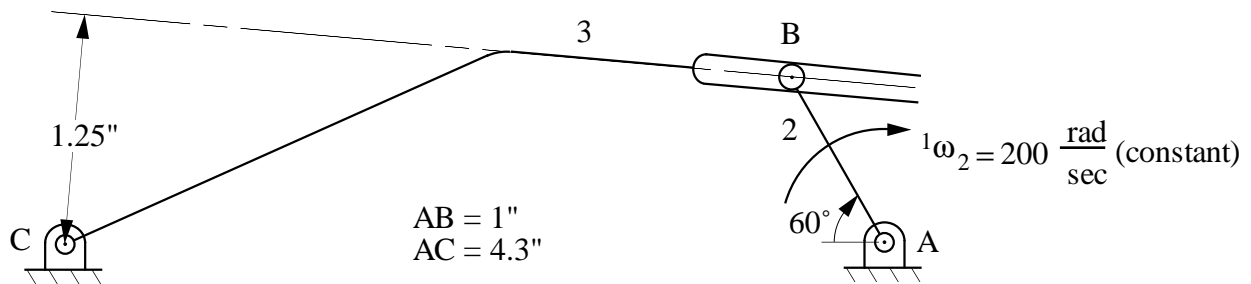

Problem S2.18

In the mechanism below, the angular velocity of Link 2 is 2 rad/s CCW and the angular acceleration is 5 rad/s² CW. Determine the following: \mathbf{v}_{B_4} , \mathbf{v}_{D_4} , $\boldsymbol{\omega}_4$, \mathbf{a}_{B_4} , \mathbf{a}_{D_4} , $\boldsymbol{\alpha}_4$, and the center of curvature of the path that B_4 traces on Link 2.

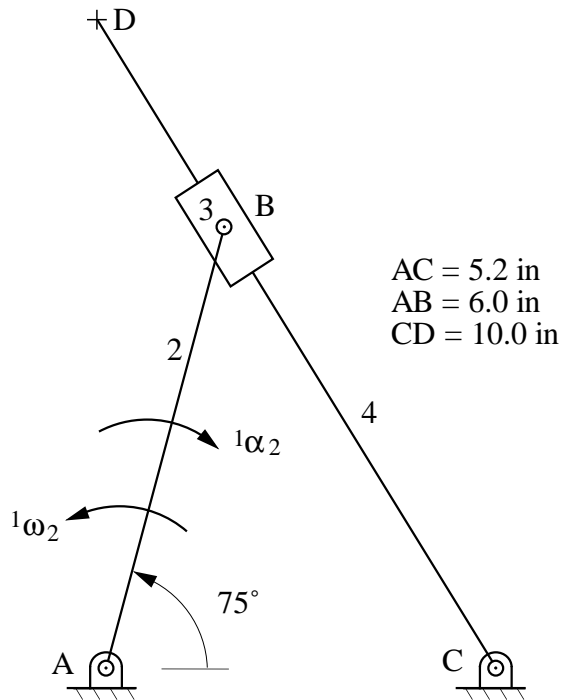

Problem S2.19

Resolve Problem S2.18 if ${}^1\omega_2 = 2$ rad/sec (constant)

Problem S2.20

If ${}^1\omega_2 = 20 \text{ rad/s}$ (constant), find ${}^1\omega_3$, ${}^1\alpha_3$, and the center of curvature of the path that C_3 traces on Link 2.

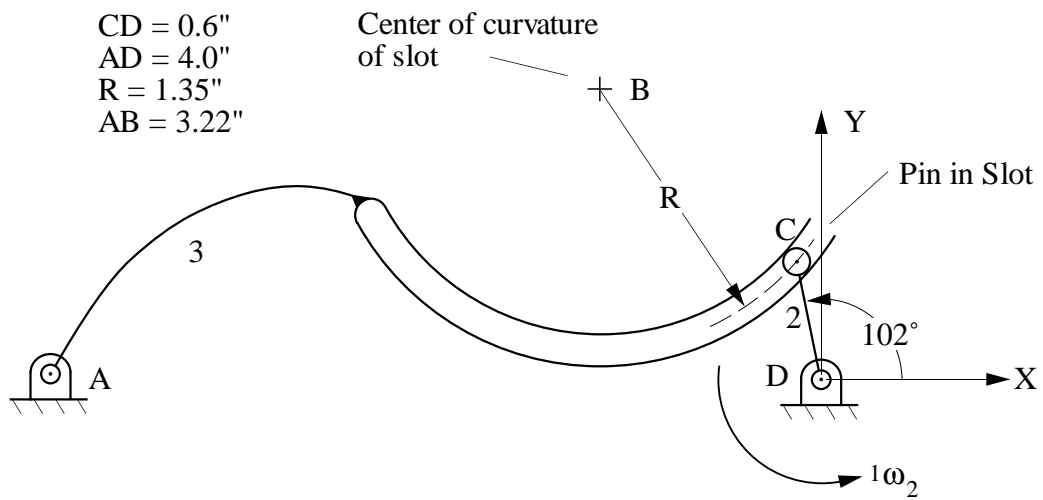

Problem S2.21

In the mechanism below, ${}^1\omega_2 = 10 \text{ rad/s}$. Complete the velocity polygon, and determine the following: ${}^1\mathbf{v}_{D_4}$, ${}^1\omega_4$, ${}^1\mathbf{v}_{F_6}$, ${}^1\omega_6$.

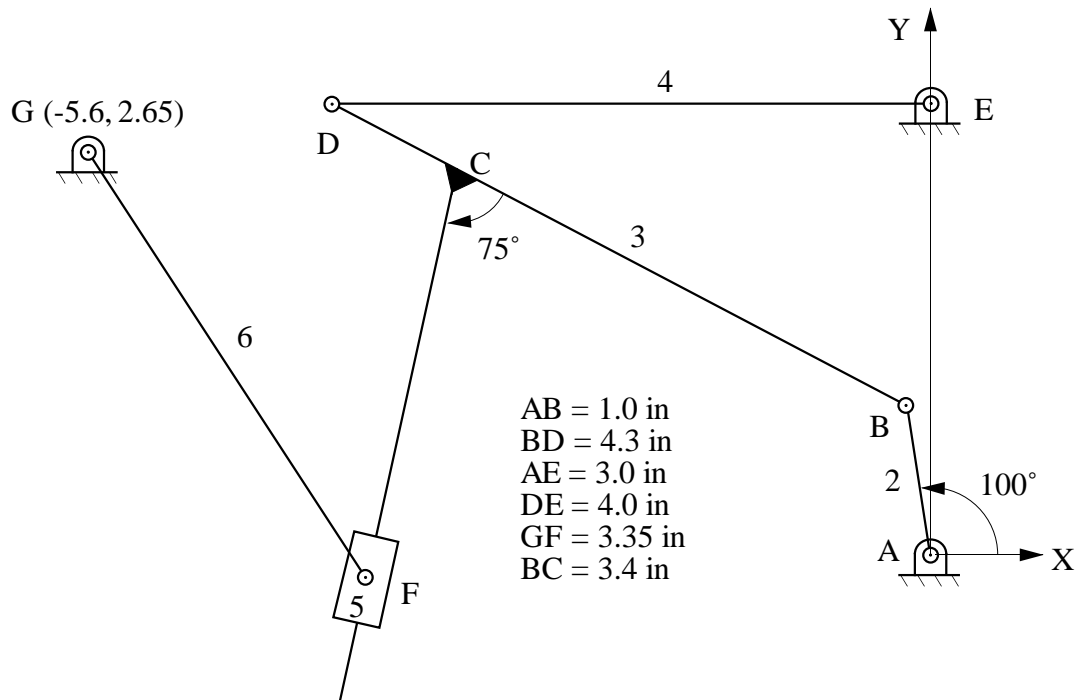

Problem S2.22

If ${}^1\omega_2 = 10 \text{ rad/s}$ (constant), find ${}^1\alpha_3$.

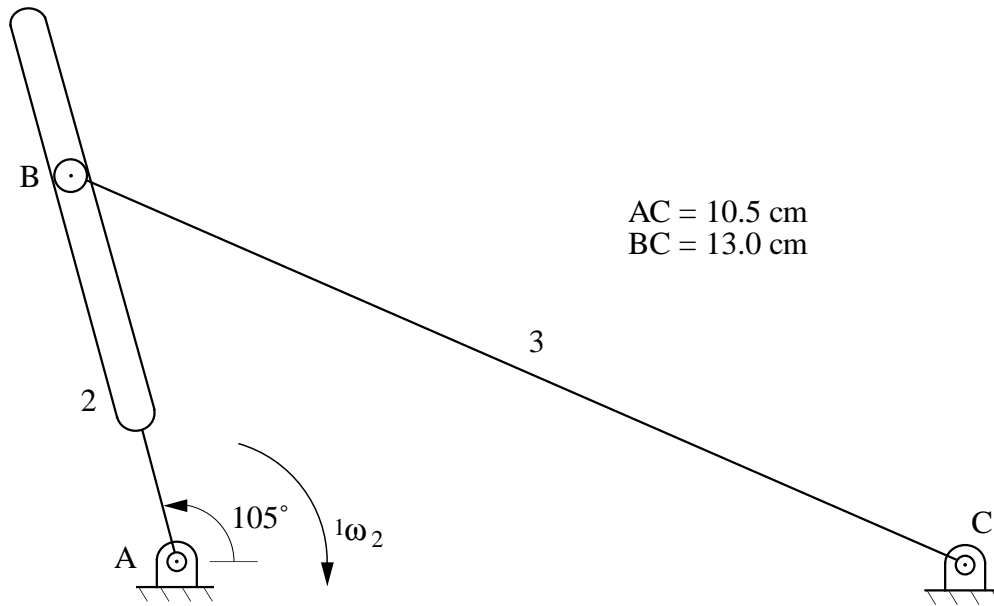

Problem S2.23

If ${}^1\omega_2 = 10 \text{ rad/s CW}$ (constant), find

- ${}^1\omega_3$
- The center of curvature of the path that B_2 traces on link 3 (show on drawing).
- The center of curvature of the path that B_3 traces on link 2 (show on drawing).

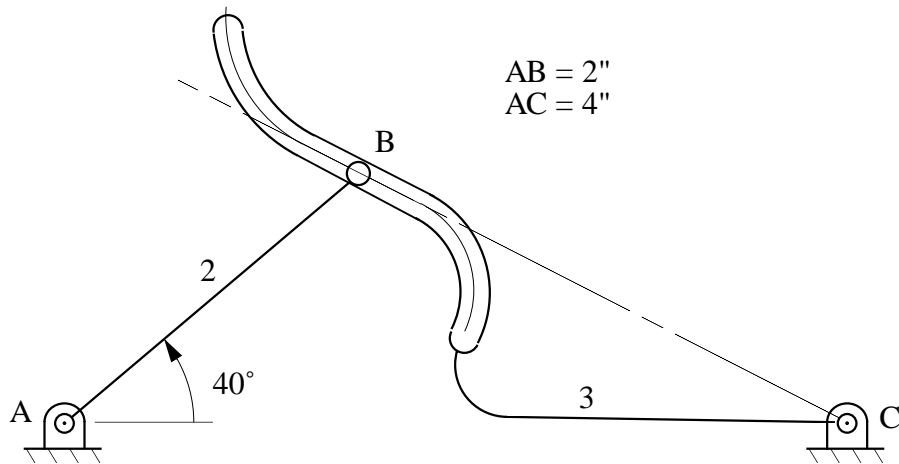

Problem S2.24

Determine the velocity and acceleration of point B on link 2.

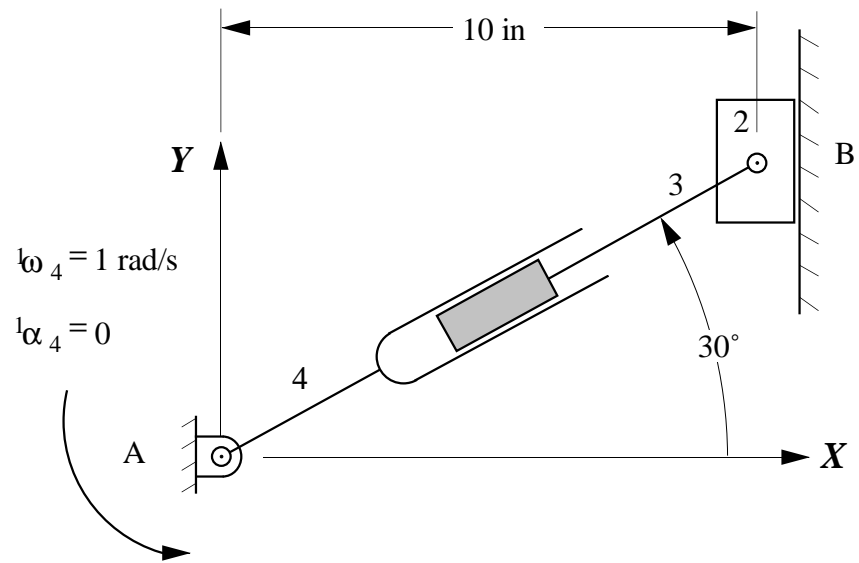

Problem S2.25

Given $v_{A_4} = 1.0$ ft/s to the left, use the instant-center method to find ${}^1\omega_2$ and then use ${}^1\omega_2$ to find v_{B_6} (direction and magnitude).

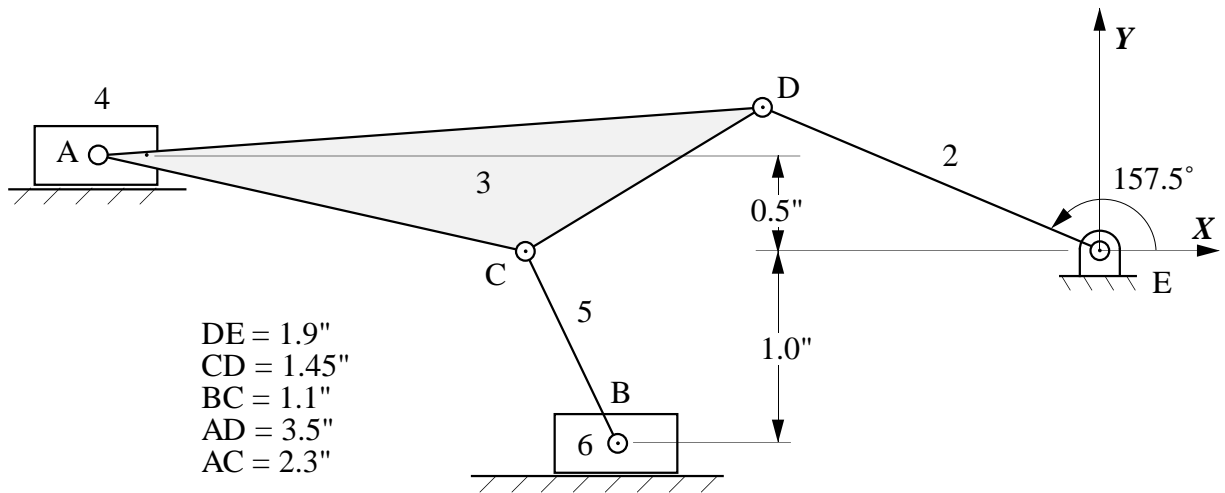

Problem S2.26

Find all of the instant centers of velocity for the mechanism shown below.

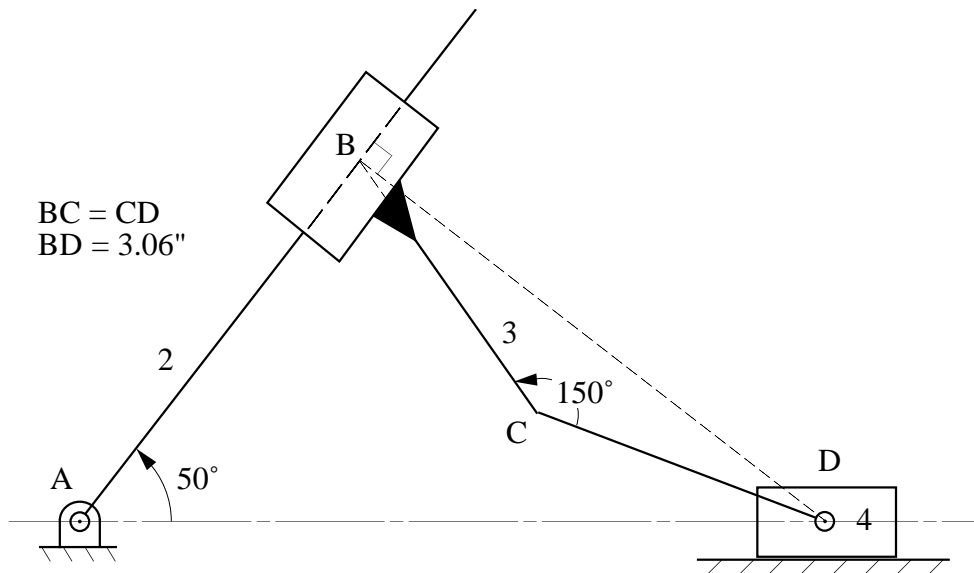

Problem S2.27

If the velocity of point A on link 2 is 10 in/s as shown, use the instant center method to find the velocity of point C on link 5.

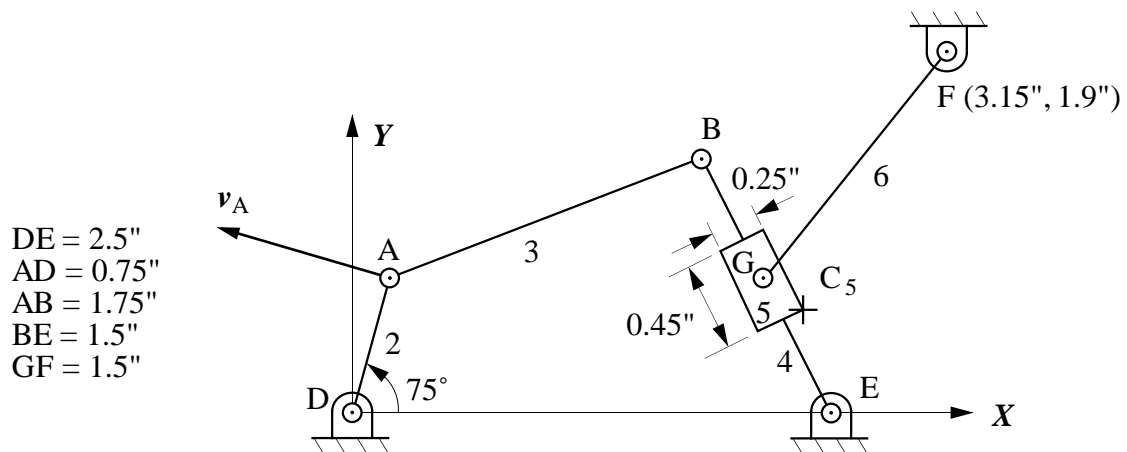

Problem S2.28

Assume that link 7 rolls on link 3 without slipping, and find the following instant centers: I_{13} , I_{15} , and I_{27} . For the given value for ${}^1\omega_2$, find ${}^1\omega_7$ using instant centers.

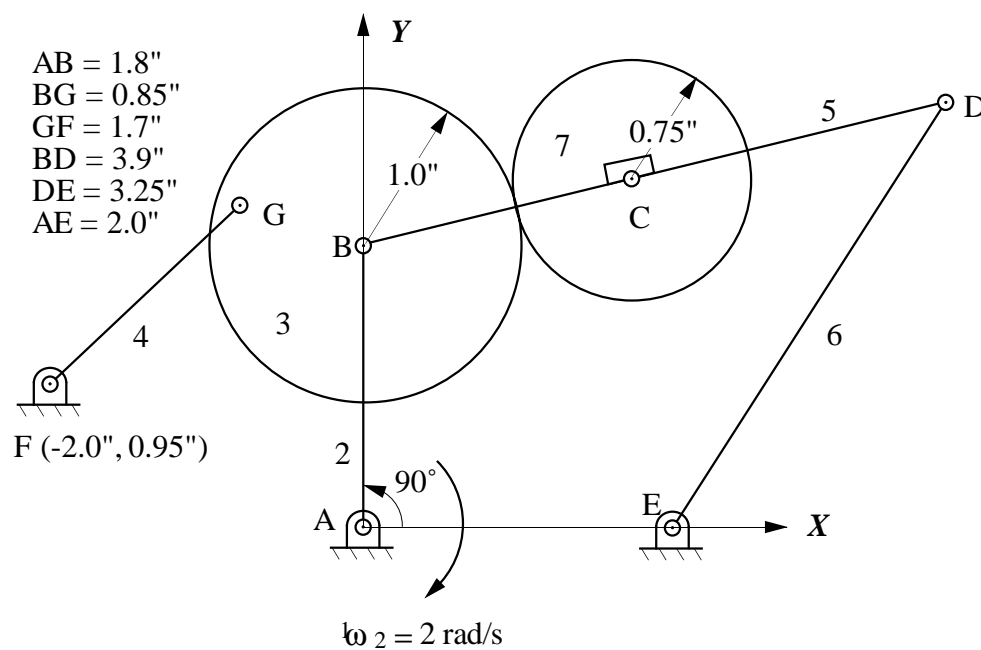

Problem S2.29

If ${}^1v_{A_2} = 10 \text{ cm/s}$ as shown, find ${}^1v_{C_5}$ using the instant-center method.

$DA = 0.95''$ $BE = 0.85''$
 $DF = 2.45''$ $EG = 2.2''$
 $AB = 1.45''$ $EC = 1.2''$
 $BF = 1.8''$ $CG = 1.25''$

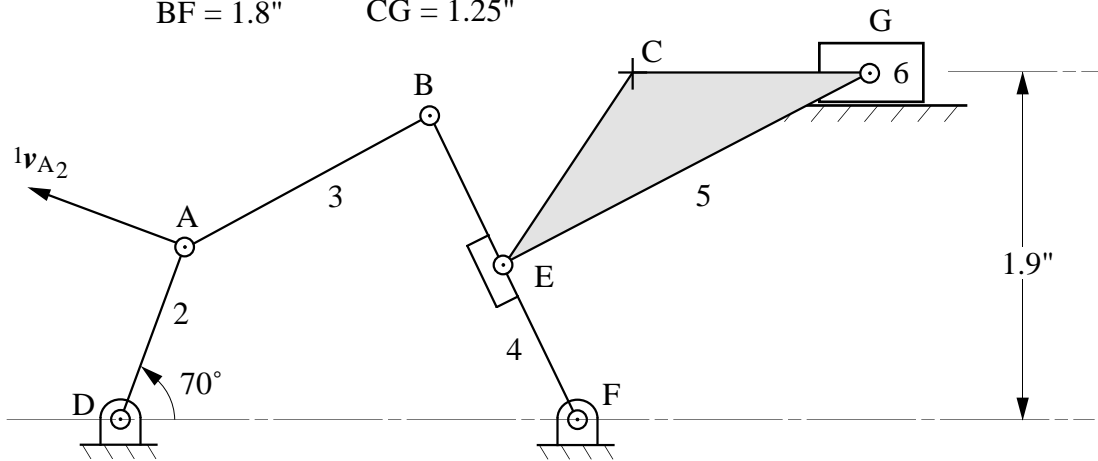

Problem S2.30

If ${}^1\omega_2 = 10 \text{ rad/s}$ CCW, find the velocity of point B using the instant-center method. Show the velocity vector ${}^1v_{B_3}$ on the figure.

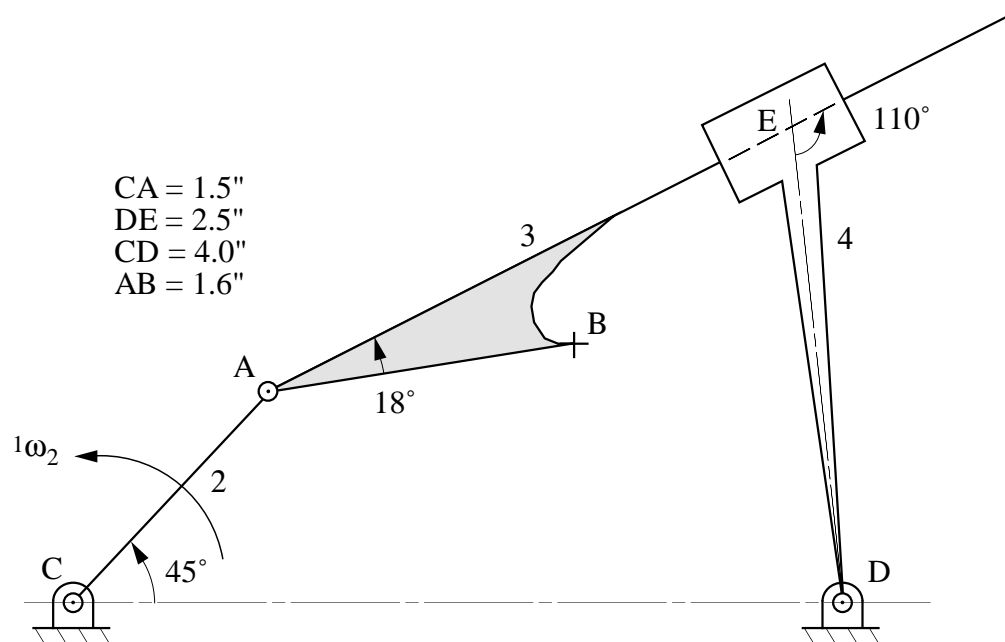

Problem S2.31

If ${}^1\omega_2 = 100 \text{ rad/s}$ CCW, find the velocity of point E using the instant center method. Show the velocity vector ${}^1v_{E4}$ on the figure.

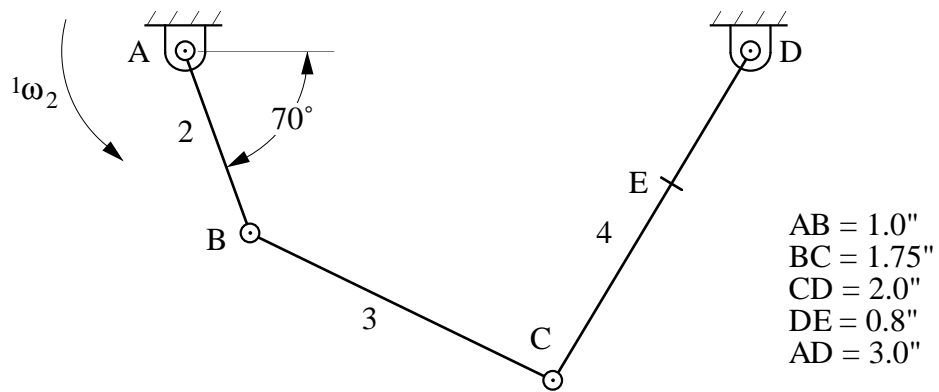

Problem S2.32

In the linkage shown below, locate all of the instant centers.

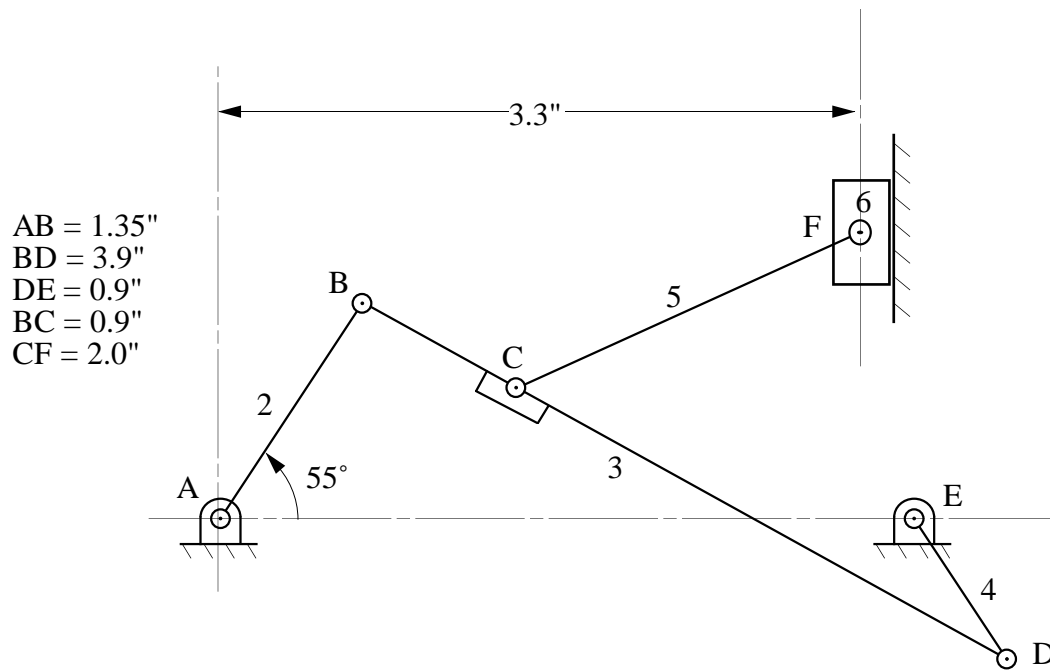

Problem S2.33

If ${}^1\omega_2 = 5 \text{ rad/s CCW}$, find ${}^1\omega_6$ using instant centers.

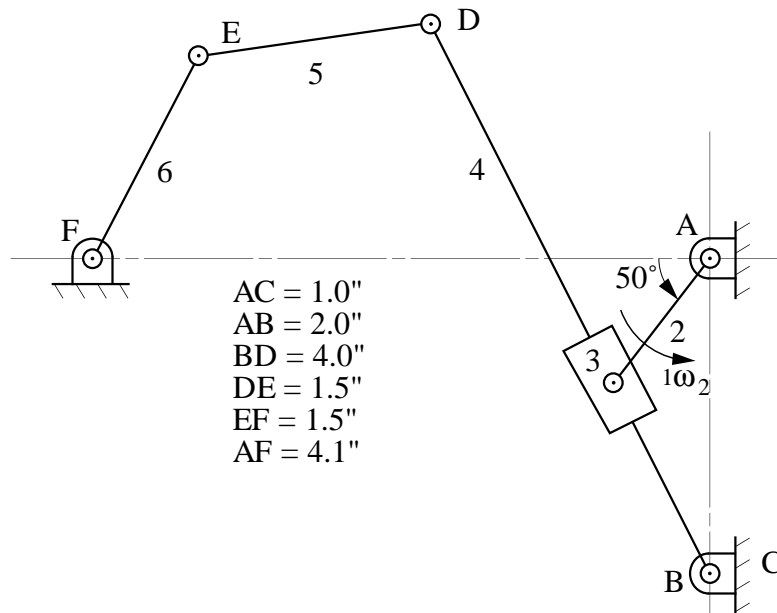

Problem S2.34

If ${}^1\omega_2 = 100 \text{ rad/s CCW}$, find ${}^1v_{B_4}$ using instant centers and the rotating radius method.

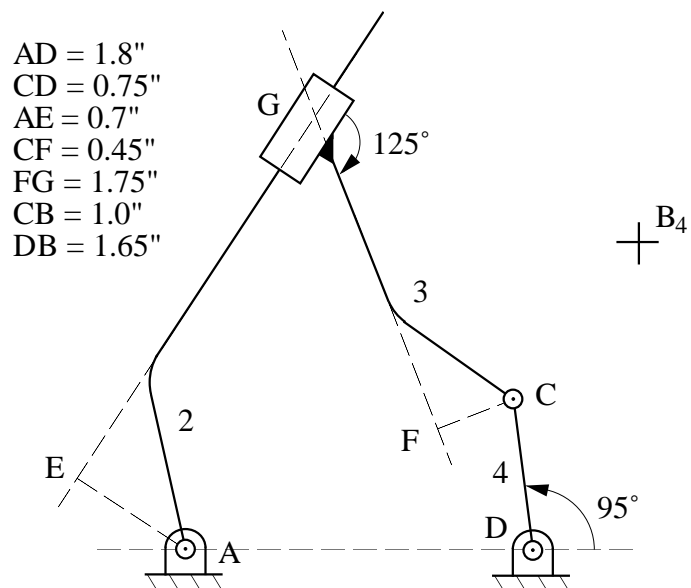

Problem S2.35

If ${}^1v_{A_2} = 10$ in/s as shown, find the angular velocity (${}^1\omega_6$) of link 6 using the instant-center method.

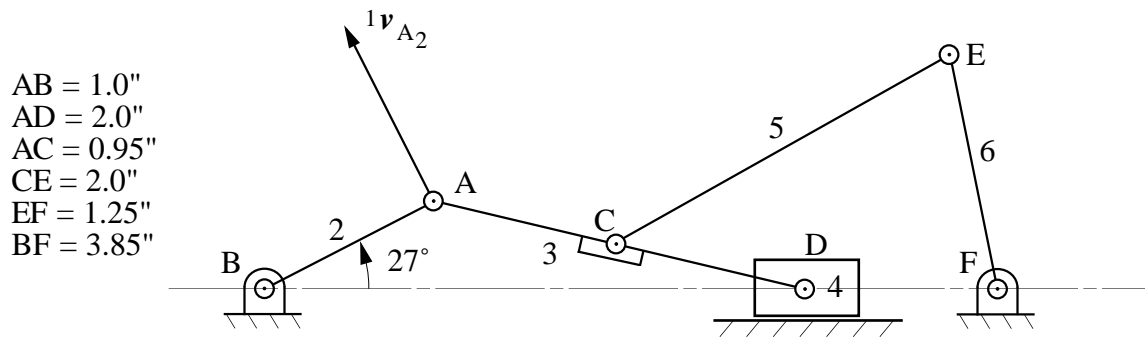

Problem S2.36

If ${}^1\omega_2 = 50 \text{ rad/s}$ CCW, find the velocity of point G using the instant center method. Show the velocity vector ${}^1v_{G_5}$ on the figure.

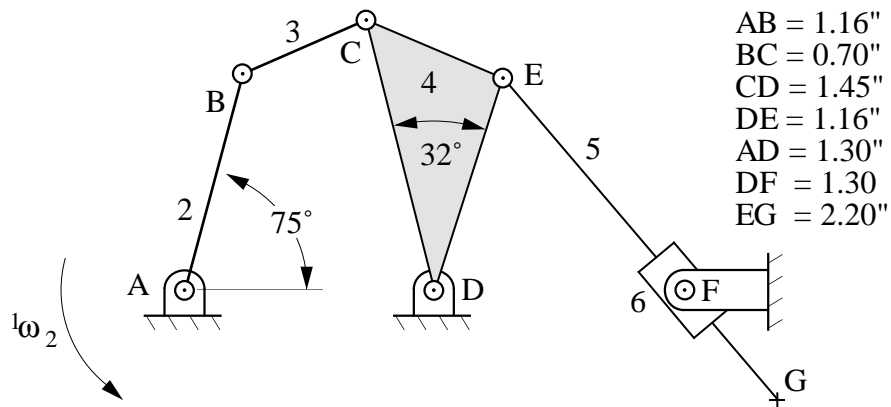

Problem S2.37

If ${}^1\omega_2 = 100 \text{ rad/s CCW}$, find ${}^1\omega_6$.

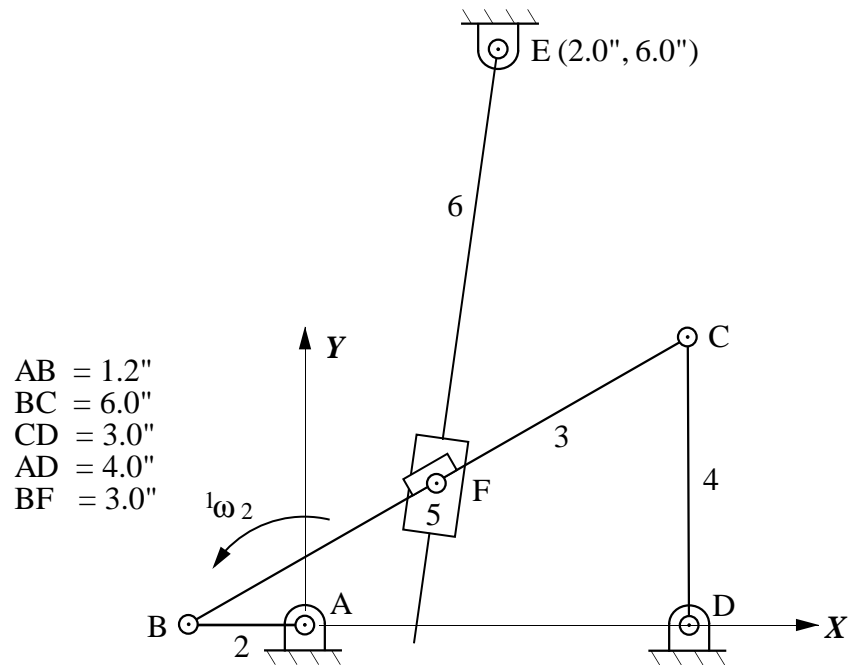

Supplemental Exercise Problems for Chapter 3

Problem 3.1

For the mechanism shown, write the loop equations for position, velocity, and acceleration. Show all angles and vectors used on the drawing and identify all variables. For the position defined by the data below, find ${}^1v_{C4}$ and ${}^1a_{C4}$ if link 2 rotates with constant angular velocity.

$$AB = 1 \text{ cm}, \quad BC = 4 \text{ cm}, \quad \theta = 90^\circ, \quad \dot{\theta} = 1 \text{ rad/s}$$

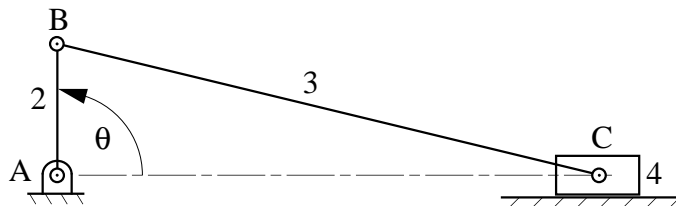

Problem 3.2

In the mechanism shown, $\dot{\phi}$ is 10 rad/s CCW. Use the loop equation approach to determine the velocity of point B_4 for the position defined by $\phi = 60^\circ$.

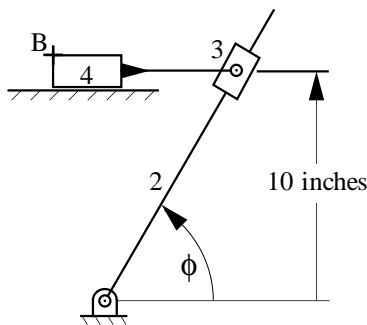

Problem 3.3

In the mechanism given, ${}^1v_{B2}$ is 10 in/s to the right (constant). Use the loop equation approach to determine ${}^1v_{A4}$ and ${}^1a_{A4}$. Use point O as the origin of your coordinate system.

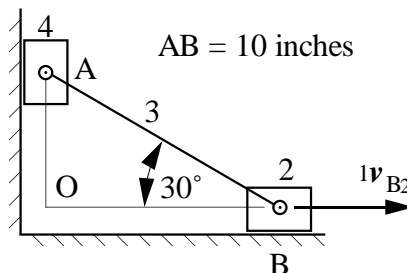

Problem 3.4

In the mechanism shown, Link 3 slides on link 2, and link 4 is pinned to link 3. Link 4 also slides on the frame (link 1). If ${}^1\omega_2 = 10 \text{ rad/s}$ CCW, use the loop-equation approach to determine the velocity of link 4 for the position defined by $\phi = 45^\circ$.

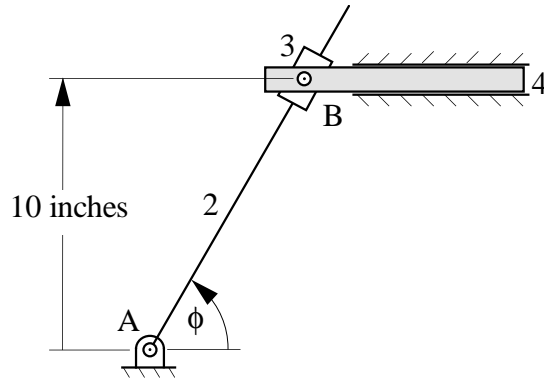

Problem 3.5

Use loop equations to determine the velocity and acceleration of point B on link 4.

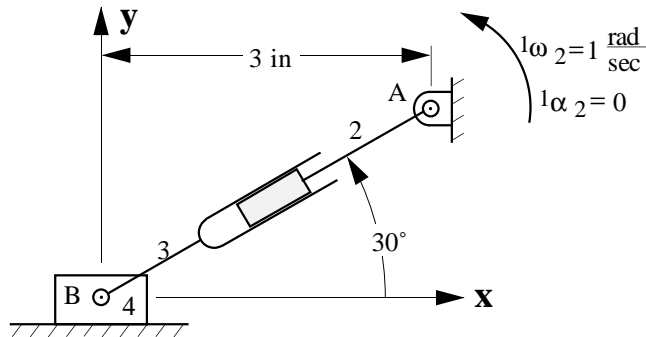

Problem 3.6

Use loop equations to determine the angular velocity and acceleration of link 3 if v_{B4} is a constant 10 in/s to the left and ${}^1\theta_3$ is 30° .

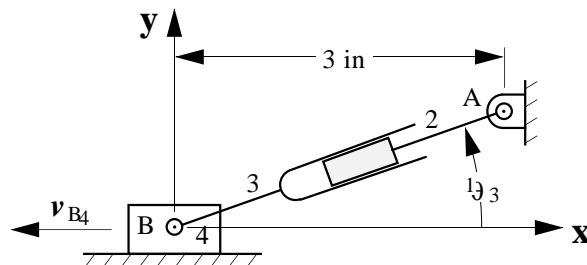

Problem 3.7

The shock absorber mechanism on a mountain bicycle is a four-bar linkage as shown. The frame of the bike is link 1, the fork and tire assembly is link 3, and the connecting linkage are links 2 and 4. As the bicycle goes over a bump in the position shown, the angular velocity of link 2 relative to the frame is ${}^1\omega_2$ is 205 (rad/s), and the angular acceleration is ${}^1\alpha_2$ is 60 (rad/s²), both in the clockwise direction. Compute the angular velocity and angular acceleration of link 3 for the position shown

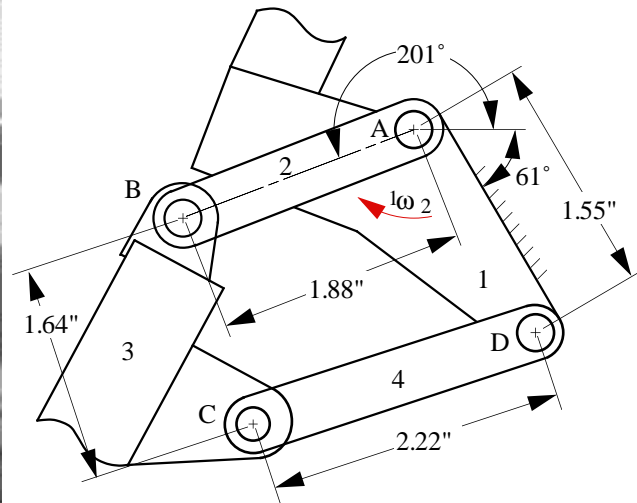
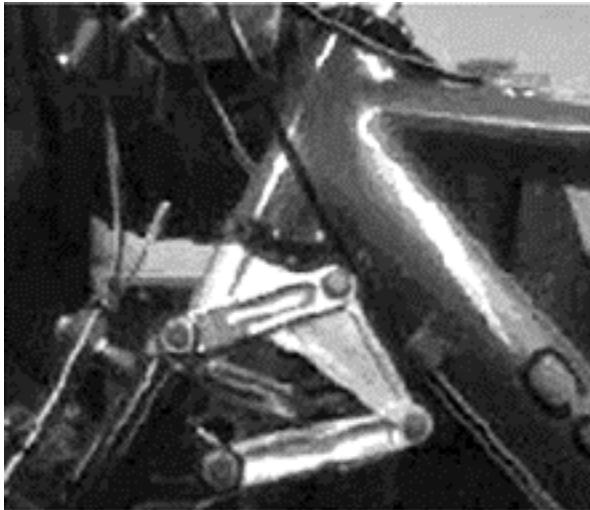

Problem 3.8

The purpose of this mechanism is to close the hatch easily and also have it remain in an open position while the owner removes items from the back. This is done by the use of an air cylinder, which helps to support the hatch while it closes and holds it up in the open position. The mechanism is an inverted slider-crank linkage, where the car acts as the base link. There are two identical linkages one on each side of the car. Assume that the angular velocity of the driver (link 2) is a constant 0.82 rad/s clockwise and the angular acceleration is 0. Compute the linear velocity of point D₂, and the angular velocity and angular acceleration of link 3 for the position shown

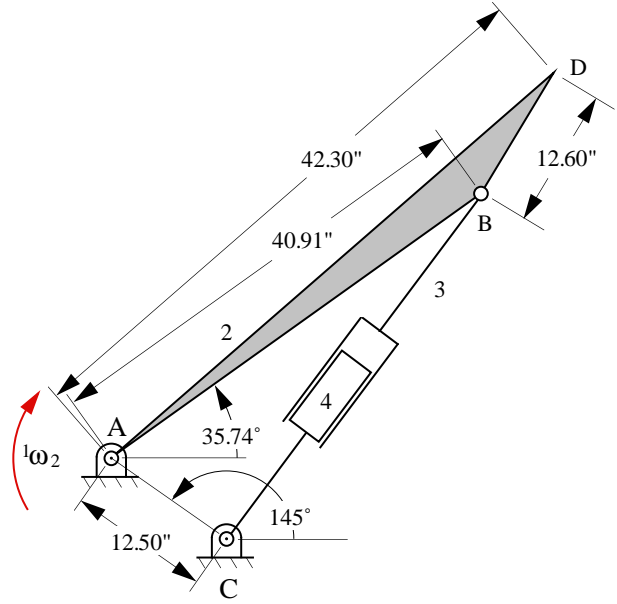

Problem 3.9

The wedge mechanism has three links and three sliding joints. Link 2 slides on link 3 and link 1. Link 3 slides on link 2 and link 1. Compute the degrees of freedom of the mechanism. Determine the relationship among β , δ , and γ which permits the mechanism to move. Assume that link 3 is the input link so that r_4 , r_1 , $\dot{\eta}_1$, and $\dot{\eta}_2$ are known. Derive expressions for $\dot{\eta}_2$, $\dot{\eta}_1$, $\dot{\eta}_2$ in terms of the variables given.

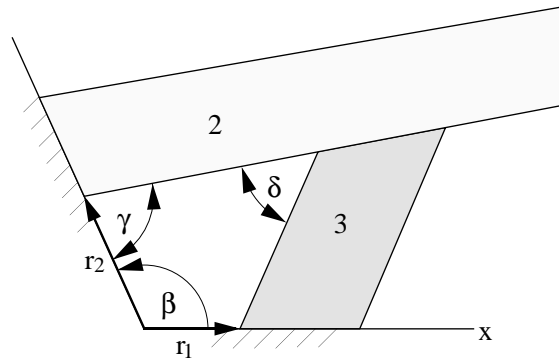

Supplemental Exercise Problems for Chapter 4

Problem S4.1

Design a four-bar linkage to move a coupler containing the line AB through the three positions shown. The moving pivot (circle point) of one crank is at A and the fixed pivot (center point) of the other crank is at C*. Draw the linkage in position 1, and use Grashof's equation to identify the type of four-bar linkage designed. Position A₁B₁ is horizontal, and positions A₂B₂ and A₃B₃ are vertical. AB = 6 cm.

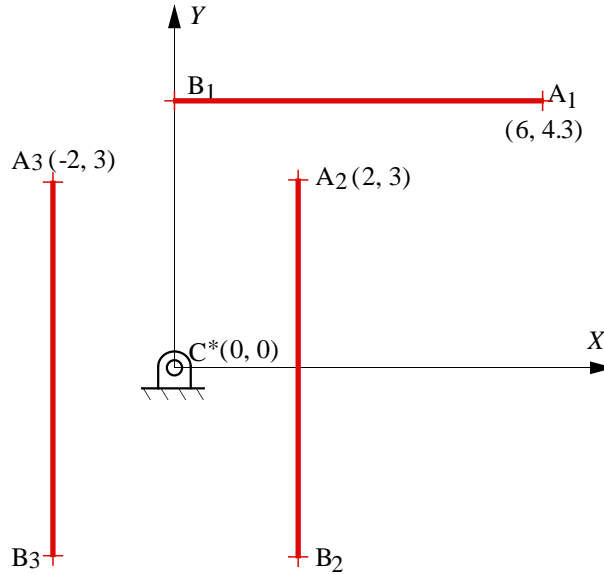

Problem S4.2

Design a four-bar linkage to move its coupler through the three positions shown below using points A and B as moving pivots. AB = 4 cm. What is the Grashof type of the linkage generated?

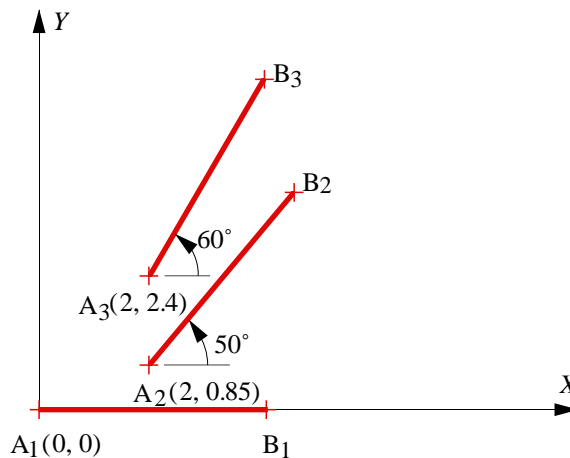

Problem S4.3

Synthesize a four-bar mechanism in position 2 that moves its coupler through the three positions shown below if points C^* and D^* are center points. Position A_1B_1 and position A_3B_3 are horizontal. $AB = 4$ cm.

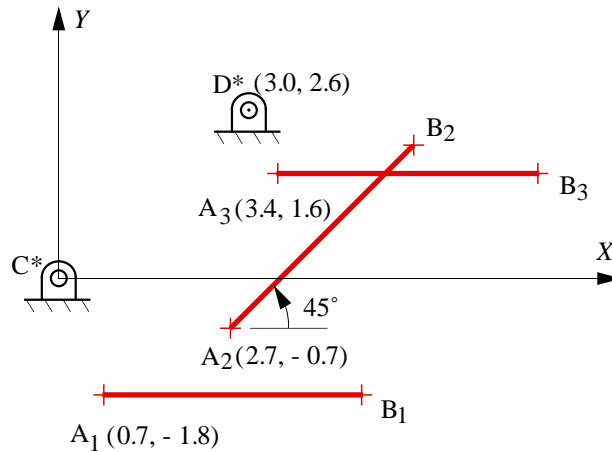

Problem S4.4

Synthesize a four-bar mechanism in position 2 that moves its coupler through the three positions shown below. Point A is a circle point, and point C^* is a center point. Position A_1B_1 and position A_3B_3 are horizontal. $AB = 4$ cm.

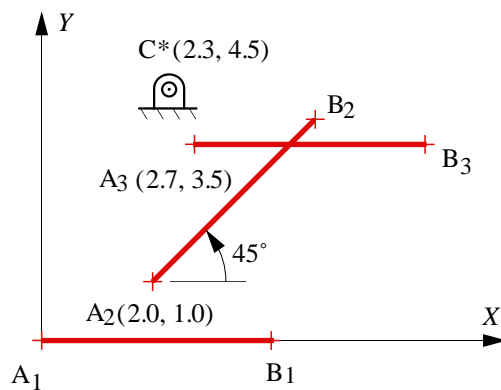

Problem S4.5

Design a four-bar linkage to move the coupler containing line segment AB through the three positions shown. The moving pivot for one crank is to be at A, and the fixed pivot for the other crank is to be at C*. Draw the linkage in position 1 and determine the classification of the resulting linkage (e.g., crank rocker, double crank). Positions A₁B₁ and A₂B₂ are horizontal, and position A₃B₃ is vertical. AB = 2.0 in.

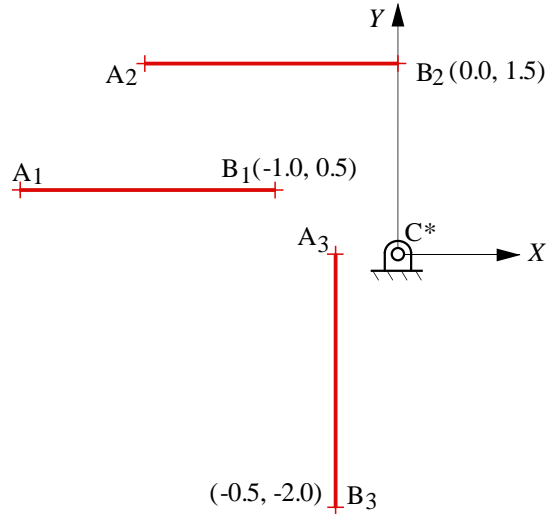

Problem S4.6

Design a four-bar linkage to move a coupler containing the line AB through the three positions shown. The moving pivot (circle point) of one crank is at A and the fixed pivot (center point) of the other crank is at C*. Draw the linkage in position 2 and use Grashof's equation to identify the type of four-bar linkage designed. Position A₁B₁ is horizontal, and positions A₂B₂ and A₃B₃ are vertical. AB = 4 in.

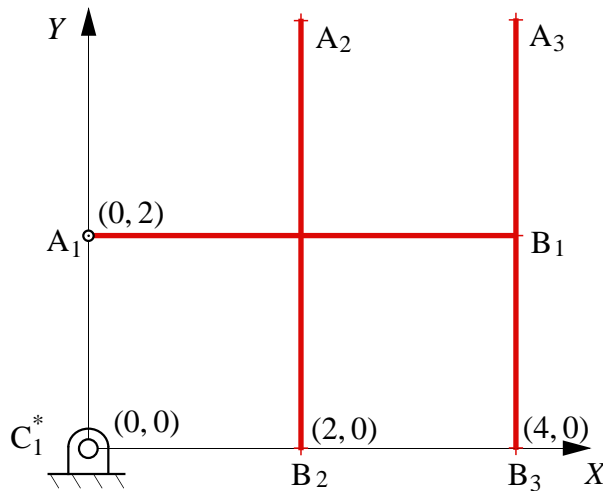

Problem S4.7

Design a four-bar linkage to generate the function $y=e^x-x$ for values of x between 0 and 1. Use Chebyshev spacing with three position points. The base length of the linkage must be 0.8 cm. Use the following angle information:

$$\begin{array}{ll} \theta_0 = 65^\circ & \Delta\theta = 60^\circ \\ \phi_0 = 40^\circ & \Delta\phi = 40^\circ \end{array}$$

Problem S4.8

Use Freudenstein's equation to design a four-bar linkage to generate approximately the function $y=1/x^2$, $1 \leq x \leq 2$. Use three precision points with Chebyshev spacing. θ is to be proportional to x and ϕ is to be proportional to y . Let $\theta_1 = 45^\circ$, $\phi_1 = 135^\circ$, $\Delta\theta = 90^\circ$, $\Delta\phi = -90^\circ$, and the base length be 2 in. Accurately sketch the linkage at the three precision point positions.

Problem S4.9

A device characterized by the input-output relationship $\phi = x_1 + x_2 \sin\theta$ is to be used to generate (approximately) the function $\phi = \theta^2$ (θ and ϕ both in radians) over the range $0 \leq \theta \leq \pi/4$.

Use Chebyshev spacing and determine the values of x_1 and x_2 which will allow the device to best approximate the function.

Problem S4.10

A mechanical device characterized by the input-output relationship $\phi = 2a_1^{2.8} + 3a_2 \tan\theta + a_3$ is to be used to generate (approximately) the function $y = 2x^3$ over the range $0 \leq x \leq \pi/4$ where x , y , ϕ , and θ are all in radians. Assume that the device will be used over the ranges $0 \leq \theta \leq \pi/4$ and $0 \leq \phi \leq \pi/3$. Exterior constraints on the design require that the parameter $a_1 = 1$. Determine:

- The number of precision points required to complete the design of the system.
- Use Chebyshev spacing, and determine the values for the unknown design variables which will allow the device to approximate the function.
- Compute the error generated by the device for $x = \pi/6$.

Problem S4.11

3. (15 points) A mechanical device characterized by the following input-output relationship:

$$\phi = 4.6p_1^{2.7*\pi} + 3p_2 \cos\theta + 2p_3$$

is to be used to generate (approximately) the function $y = 2\sqrt{x}$ over the range $0 \leq x \leq \frac{\pi}{4}$ where x , y , ϕ , and θ are all in radians. Assume that the device will be used over the ranges $0 \leq \theta \leq \frac{\pi}{3}$ and $0 \leq \phi \leq \frac{\pi}{3}$. The problem is such that you may pick any value for any one of the design variables and solve for the other two; i.e., pick a value for one of p_1 , p_2 , p_3 and solve for the other two.

Determine:

- 1) The number of precision points required to complete the design of the system.
- 2) Use Chebyshev spacing, and determine the values for the unknown design variables which will allow the device to approximate the function.
- 3) Compute the error generated by the device for $x = \pi/6$.

Problem S4.12

Design a crank-rocker mechanism such that with the crank turning at constant speed, the oscillating lever will have a time ratio of advance to return of 3:2. The lever is to oscillate through an angle of 80° , and the length of the base link is to be 2 in.

Problem S4.13

Design a crank-rocker mechanism which has a base length of 1.0, a time ratio of 1.25, and a rocker oscillation angle of 40° . The oscillation is to be symmetric about a vertical line through O_4 . Specify the length of each of the links.

Problem S4.14

Determine the two 4-bar linkages cognate for the drag-link mechanism shown. The dimensions are $MQ = 1$ m, $AM = BQ = 4$ m, $AB = 2$ m, and angles CAB and CBA both equal 45° . Notice that the cognates will also be drag-link mechanisms. Draw the cognates in the position for $\theta = 180^\circ$.

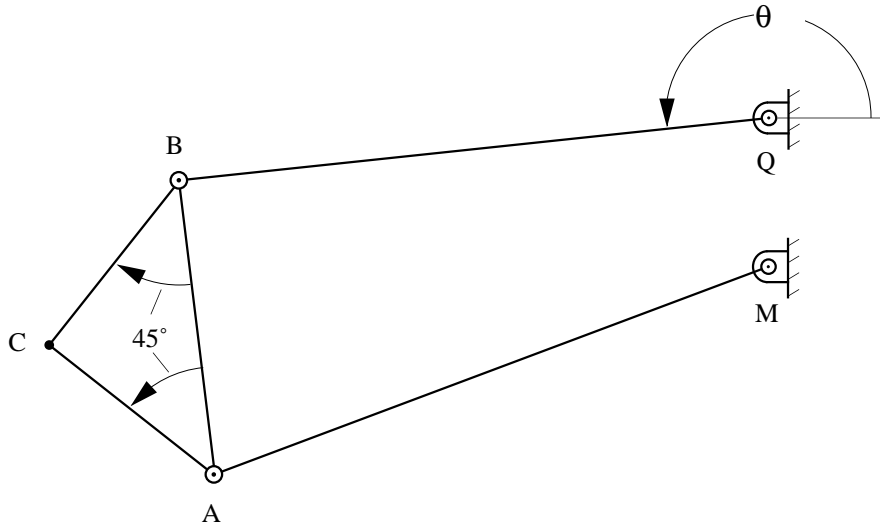

Supplemental Exercise Problems for Chapter 5

No supplemental problems were developed for Chapter 5.

Supplemental Exercise Problems for Chapter 6

Problem S6.1

Assume that s is the cam-follower displacement and θ is the cam rotation. The rise is 1.0 cm after β degrees of rotation, and the rise begins at a dwell and ends with a constant-velocity segment. The displacement equation for the follower during the rise period is

$$s = h \sum_{i=0}^n C_i \left(\frac{\theta}{\beta} \right)^i$$

- a) If the position, velocity, and acceleration are continuous at $\theta = 0$, and the position and velocity are continuous at $\theta = \beta$, determine the n required in the equation, and find the coefficients C_i which will satisfy the requirements.
- b) If the follower is a radial flat-faced follower and the base circle radius for the cam is 1 cm, determine whether the cam will have a cusp corresponding to $\theta = 0$. Show all equations used.

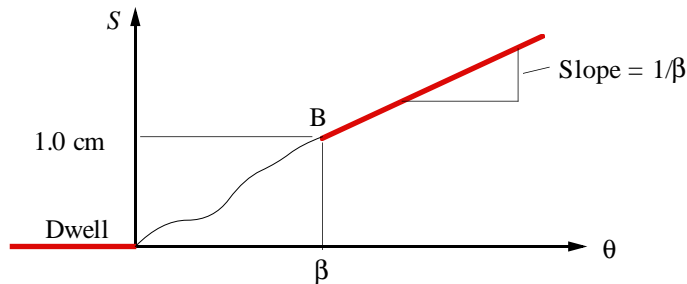

Problem S6.2

Assume that s is the cam-follower displacement and θ is the cam rotation. The rise is h after β radians of rotation, and the rise begins and ends at a dwell. The displacement equation for the follower during the rise period is

$$s = h \sum_{i=0}^n C_i \left(\frac{\theta}{\beta} \right)^i$$

At A, dynamic effects are important, so displacement, velocity, and acceleration must be continuous there. At B only displacement and velocity are important. To satisfy these conditions, determine the number of terms required and the corresponding values for the coefficients C_i if the cam velocity is constant.

If h is 1 cm and β is 90° , determine the minimum base circle radius to avoid cusps if the cam is used with a flat-faced follower.

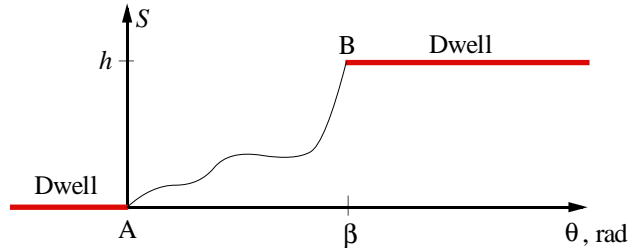

Problem S6.3

Resolve Problem 6.12 if the cam velocity is 2 rad/s constant. Note: Use the minimum number of C_i possible. If h is 3 cm and β is 60° , determine the minimum base circle radius to avoid cusps if the cam is used with a flat-faced follower.

Problem S6.4

For the cam displacement schedule given, h is the rise, β is the angle through which the rise takes place, and s is the displacement at any given angle θ . The displacement equation for the follower during the rise period is

$$s = h \sum_{i=0}^5 a_i \left(\frac{\theta}{\beta} \right)^i$$

Determine the required values for $a_0 \dots a_5$ such that the displacement, velocity, and acceleration functions are continuous at the end points of the rise portion.

If h is 1 cm and $\beta = \pi/3$, determine the minimum base circle radius to avoid cusps if the cam is used with a flat-faced follower.

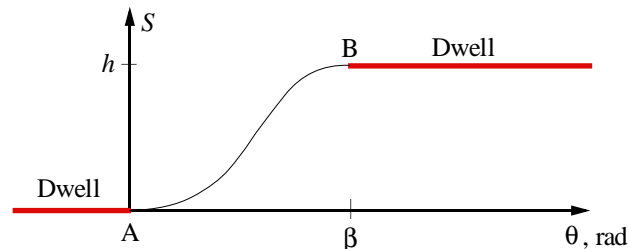

Problem S6.5

Resolve Problem 6.14 if the cam will be used for a low-speed application so that acceleration effects can be neglected. Determine the number of terms required and the corresponding values for the constants (C_i) if the displacement and velocity are continuous at the end points of the rise (points A and B) and if the cam velocity is constant.

If h is 1 cm and β is 90° , determine the minimum base circle radius to avoid cusps if the cam is used with a flat-faced follower.

Problem S6.6

Lay out a cam profile using a harmonic follower displacement profile for both the rise and return. The cam is to have a translating, flat-faced follower which is offset in the clockwise direction by 0.2 in. Assume that the follower is to dwell at zero lift for the first 100° of the motion cycle and to dwell at 1 in lift for cam angles from 220° to 240° . The cam will rotate clockwise, and the base circle radius is to be 2 in. Lay out the cam profile using 20° plotting intervals.

Supplemental Exercise Problems for Chapter 7

Problem S7.1

In the manipulator shown, the joint axes at A and B are oriented along the z and m axes, respectively. In the position to be analyzed, link 2 lies in a plane parallel to the XY plane and points along a line parallel to the Y axis, and link 3 is perpendicular to link 2. For the position to be analyzed, link 3 is vertical (parallel to Z). The joint between link 2 and the frame at A is a cylindrical joint, and that at B is a revolute joint. Determine ${}^1\mathbf{v}_{C3/A1}$, ${}^1\mathbf{a}_{B3/A1}$, and ${}^1\boldsymbol{\alpha}_3$.

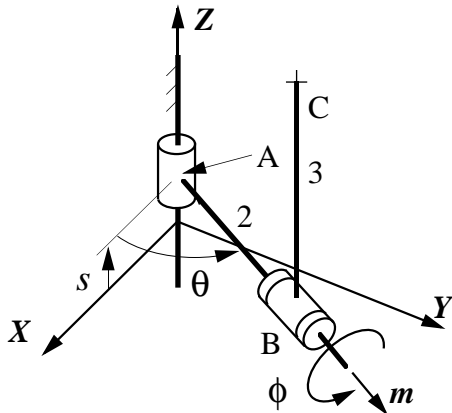

$$\theta = 90^\circ, \quad \dot{\theta} = 1 \text{ rad/s}, \quad \ddot{\theta} = 0 \text{ rad/s}^2,$$

$$\phi = 1 \text{ rad/s}, \quad \ddot{\phi} = 0 \text{ rad/s}^2,$$

$$\dot{s} = 0 \text{ in/s}, \quad \ddot{s} = 1 \text{ in/s}^2,$$

$$\overline{AB} = 1 \text{ in}, \quad \overline{BC} = 1 \text{ in}$$

Supplemental Exercise Problems for Chapter 8

No supplemental problems were developed for Chapter 8.

Supplemental Exercise Problems for Chapter 9

No supplemental problems were developed for Chapter 9.

Supplemental Exercise Problems for Chapter 10

Problem S10.1

An alternative gear train is shown as a candidate for the spindle drive of a gear hobbing machine. The gear blank and the worm gear (gear 9) are mounted on the same shaft and rotate together. If the gear blank is to be driven clockwise, determine the hand of the hob. Next determine the velocity ratio (ω_3 / ω_5) to cut 75 teeth on the gear blank. Finally, select gears 3 and 5 which will satisfy the ratio. Gears are available which have all of the tooth numbers from 15 to 40.

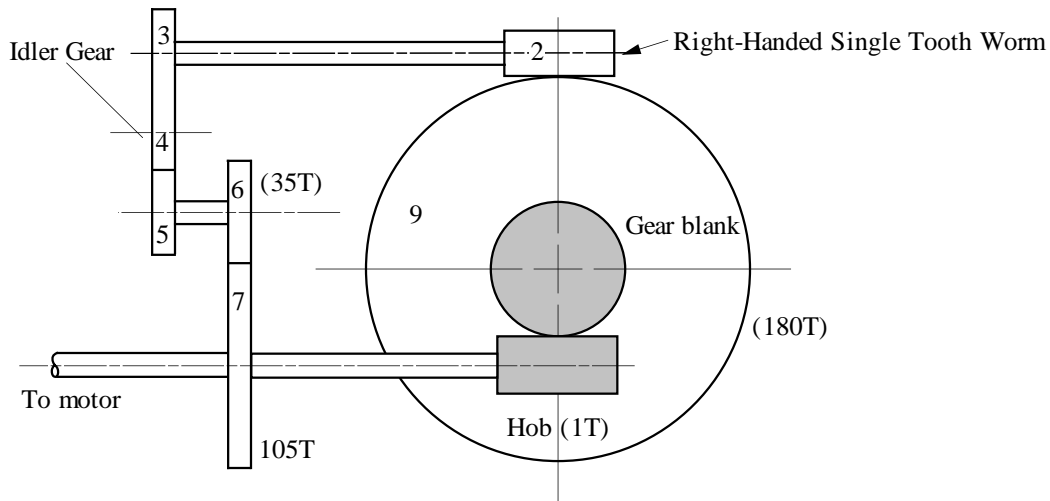

Problem S10.2

A simple gear reduction unit is to be used to generate the gear ratio 2.105399. Make up a table of possible gear ratios where the maximum number of teeth on all gears is 100. Identify the gear set that most closely approximates the desired ratio. Note that this can be done most easily with a computer program. What is the error?

Problem S10.3

Resolve Problem 10.20 when $N_2 = 80T$, $N_3 = 30T$, $N_4 = 20T$ and $N_5 = 130$.

Problem S10.4

In the mechanism shown, let the input be gear 2 and assume that all of the gear tooth numbers (N_2 , N_3 , N_4 , N_5 , N_6 , N_7 , and N_8) are known. Derive an expression for the angular velocity of gear 8.

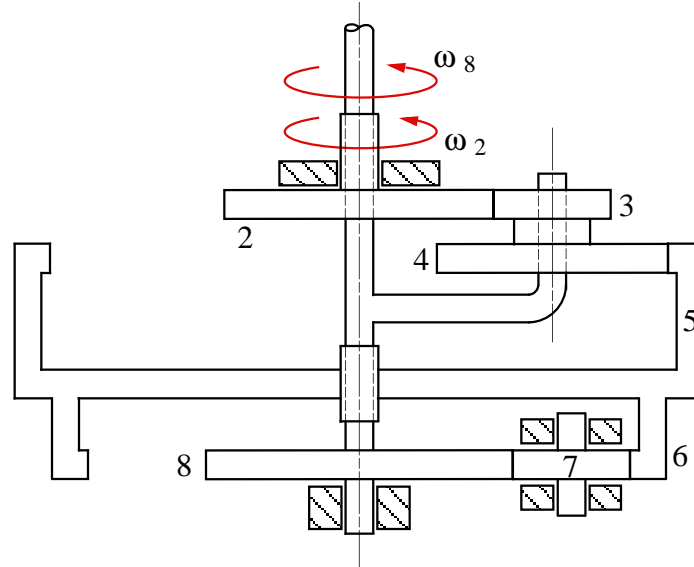

Problem 10.5

In Problem S10.4, assume that $\omega_2 = 50 \text{ rpm}$, $N_2 = 60$, $N_3 = 30$, $N_4 = 50$, $N_5 = 140$, $N_6 = 120$, $N_7 = 20$, and $N_8 = 80$. Determine the angular velocity of gear 8.

Supplemental Exercise Problems for Chapter 11

Problem S11.1

Find the torque T_{12} for a coefficients of friction μ of 0.0 and 0.2. Consider friction at the slider only and neglect the masses of the links.

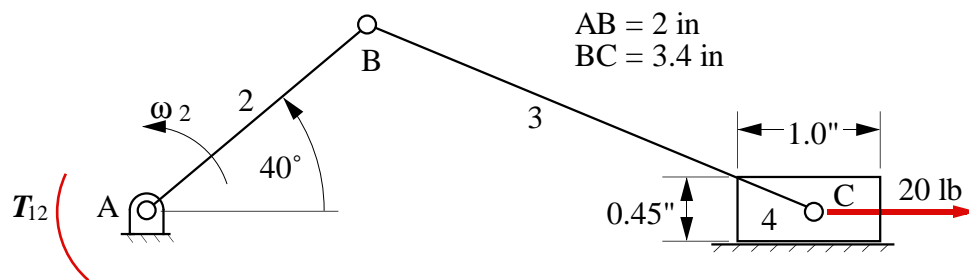

Supplemental Exercise Problems for Chapter 12

Problem S12.1

A uniform rectangular plate is suspended from a rail by means of two bogies as shown. The plate is connected to the bogies by means of frictionless hinge joints at A and at B. At time $t=0$ the pin of joint B breaks, allowing the plate to swing downward. Write the equations of motion of the plate as it starts to move. Hence find its initial angular acceleration and the initial acceleration of point A.

You may assume that the rollers which support point A are frictionless and that they remain in contact with the rail. You may also assume that the angular displacement from the initial position is small. The moment of inertia of a uniform rectangular plate with sides $2a$ and $2b$ about an axis normal to its plane passing through its centroid is $m(2a+2b)/12$, where m is the mass of the plate.

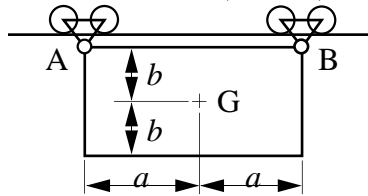

Supplemental Exercise Problems for Chapter 13

Problem S13.1

For the mechanism and data given, determine the shaking force and its location relative to point A. Draw the shaking force vector on the figure.

$${}^1\omega_2 = 210 \text{ rad/s CCW}$$

$${}^1\alpha_2 = \text{rad/s}^2$$

$$W_2 = 3.40 \text{ lb}$$

$$I_{G_3} = 0.1085 \text{ lb-s}^2\text{-in}$$

$$W_3 = 3.40 \text{ lb}$$

$$W_4 = 2.85 \text{ lb}$$

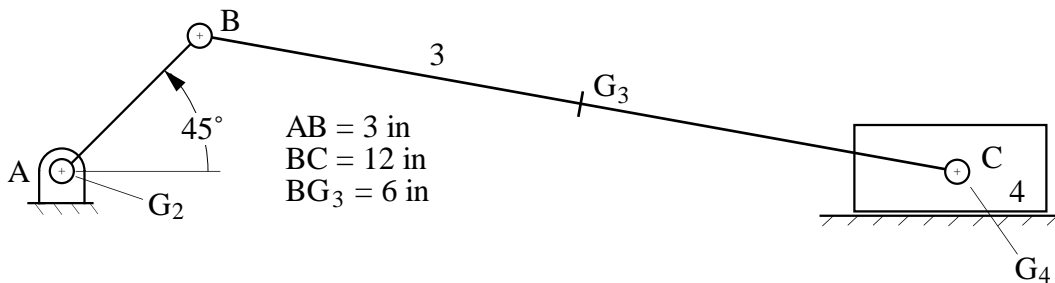

Problem S13.2

For the engine given in Problem 13.11, lump the weight of the connecting rod at the crank pin and piston pin and locate the counterbalancing weight at the crank radius. Determine the optimum counterbalancing weight which will give

1. The smallest horizontal shaking force
2. The smallest vertical shaking force

Problem S13.3

Resolve Problem 13.16 for the following values for the phase angles and offset distances.

$$\begin{array}{cccc}
 \phi_1 = 0 & \phi_2 = 180^\circ & \phi_3 = 90^\circ & \phi_4 = 270^\circ \\
 a_1 = 0 & a_2 = a & a_3 = 2a & a_4 = 3a
 \end{array}$$

Problem S13.4

The four-cylinder V engine shown below has identical cranks, connecting rods, and pistons. The rotary masses are perfectly balanced. Derive an expression for the shaking forces and shaking moments for the angles and offset values indicated. The V angle is $\psi = 60^\circ$, and the phase angle is $\phi_2 = 180^\circ$. Are the primary or secondary shaking forces balanced? What about the primary and

secondary shaking moments? Suggest a means for balancing any shaking forces or couples which result.

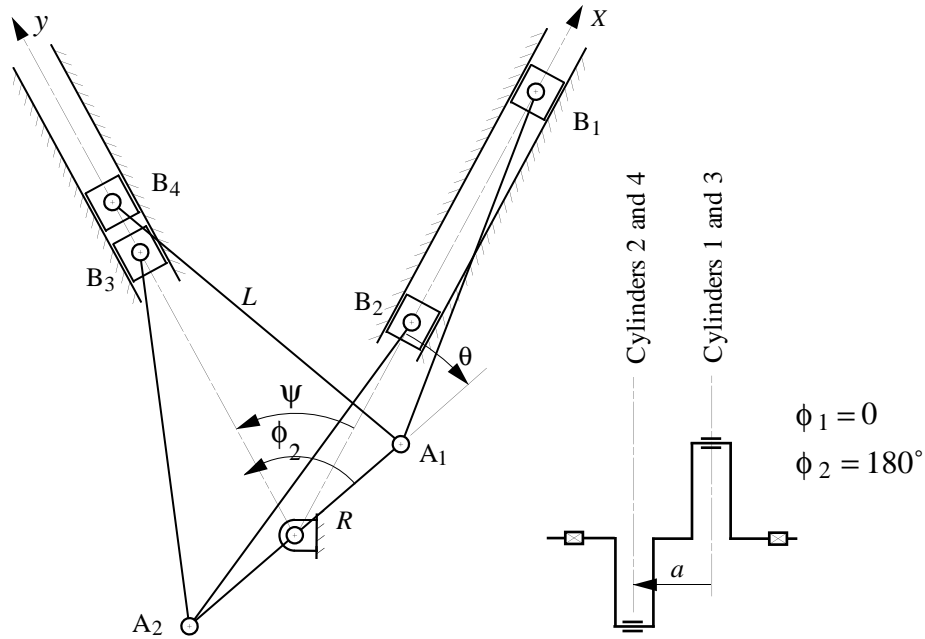

Problem S13.5

Resolve Problem S13.4 if the V angle is $\psi = 90^\circ$. Estimate the optimum value for ψ .

Problem S13.6

Assume that a seven-cylinder in-line engine is being considered for an engine power plant. The engine is characterized by the following phase angles:

$$\phi_1 = 0, \phi_2 = 90^\circ, \phi_3 = 180^\circ, \phi_4 = 180^\circ, \phi_5 = 0^\circ, \phi_6 = 120^\circ, \text{ and } \phi_7 = 240^\circ$$

$$a_1 = 0, a_2 = a, a_3 = 2a, a_4 = 3a, a_5 = 4a, a_6 = 5a, \text{ and } a_7 = 6a$$

Determine the type of unbalance which exists in the engine.